



**OR broag - remeha**

*Advanced boiler technology*

# OD13A boiler

## Pressure-jet oil fired boilers Gas fired standard or fully condensing boilers

The Broag Seagold OD 13A series is part of a family of advanced technology cast iron sectional boilers manufactured under BS 5750 and ISO 9001 quality assurance procedures by an award winning company with a 55-year record of leadership throughout Europe.

In either oil/gas fired standard or gas fired fully condensing formats the OD 13A can radically reduce heating costs in schools, libraries, office buildings, nursing homes and other midrange private and public sector applications.

### High efficiency

In standard format, the OD 13A operates at efficiencies of 86% on full load and 88% on part load.

The boiler's exceptionally large combustion area is shaped to correspond with modern burner patterns. Aided by high turbulence flueways, the combustion gases traverse its entire length, achieving maximum heat transfer. Special return header design ensures uniform water distribution.

### Higher efficiency

The optional Condensing Unit can be fitted as original equipment, or retrofitted. It is a secondary heat exchanger that recovers 'lost' heat from the spent combustion gases.

This allows output to be maintained on less fuel and lower water return temperatures.

Efficiencies are enhanced to 90% and beyond on both full and part load, while environmentally unfriendly dioxide emissions are reduced by 25% as a free part of the bargain.

### Easier installation

The OD 13A is constructed from immensely durable, corrosion resistant and heat-conductive pearlitic cast iron sections which can operate with a minimum return temperature of 45°C on gas and 40°C on oil.

Delivered protectively packaged and palletted, the sections are small and light enough to be man handled and to negotiate standard doorways and stairways to rooftop and basement boilerhouse sites.

### Simpler erection

The OD 13A may be mounted directly onto any level fireproof plantroom floor suitably stressed to withstand the water-charged boiler and its ancillary equipment. (If you prefer to prepare a special base, see the relevant diagram for dimensions.)

The two necessary steel mounting girders are supplied, and anti-vibration bars are optional.

Boiler sections are cast to strictly uniform thickness, are carefully machined on all mating surfaces and have a tapered nipple profile that ensures positive integration.

### Faster commissioning

OD 13A boilers are supplied for open vent and closed systems. Standard operating pressure is 4

bar, or up to 6 bar on request. The boilers can also operate with a flow temperature up to 110°C.

Flow and return connections are at the rear of the boiler with 2½" counter flanges for welding. The return connection has a ¾" tapped boss for drain connection.

The boiler may be connected to the system and test fired without its red and grey enamelled steel casings in place. These can then be fitted without breaking any water connection. Their protective plastic coating should then be removed.

### Some advisory notes

Boilers and ancillaries not being installed immediately should be protected from weather and adverse site conditions.

In hard water areas, all water, from the first fill

onwards, should be treated to prevent lime scale build-up and impairment of boiler performance.

Erection and commissioning should be carried out by Broag engineers, or by qualified third party installers in accordance with the Assembly Instructions booklet.

### Other Broag Seagold choices

The OD 13A is part of an OD model range with ratings up to 1,884kW. The total Broag Seagold family of atmospheric, blown and fully condensing boilers offers ratings from 12kW to 2,000kW with multiple-boiler installations and containerised boilerhouses extending the choice still further.

Whatever your heating requirements Broag Seagold can meet them more cleanly and cost-effectively.

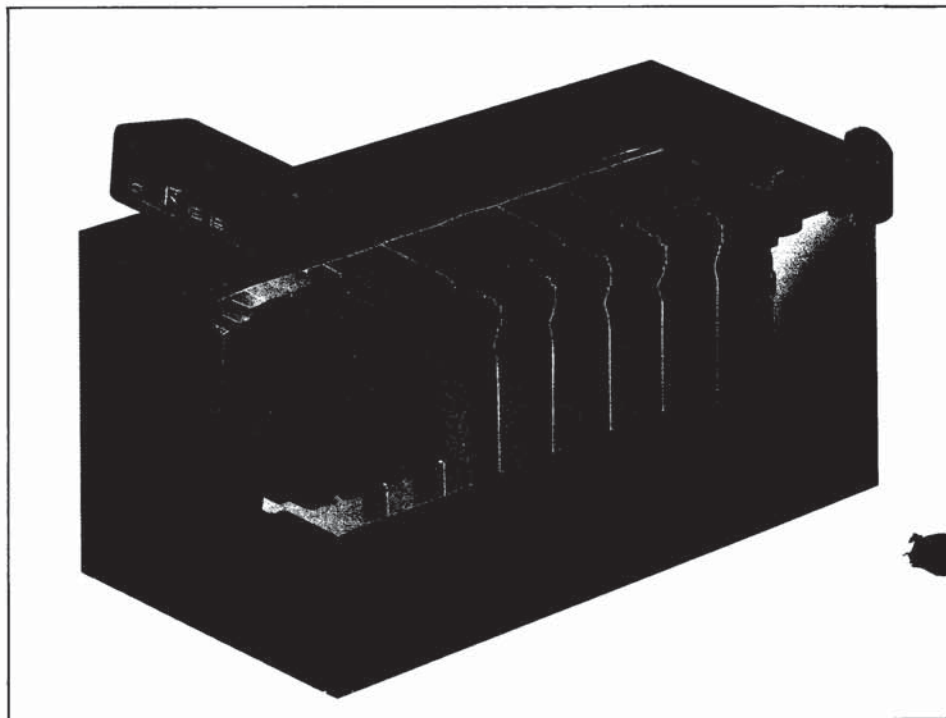

Dissected OD series boiler. Exposed: the special boiler shape, greater combustion area, high turbulence flueways and other features by which this positive-direction 3-pass boiler achieves efficiencies up to 86% – even before you fit the optional condensing unit.

Broag Seagold boilers are manufactured by a BSi registered company to BS 5750, Part 1, Certificate No. FM 1635.

## Boiler dimensions OD 13A

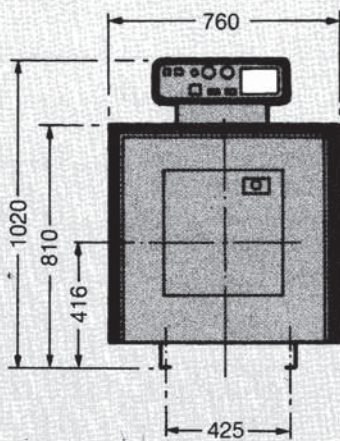

FRONT VIEW

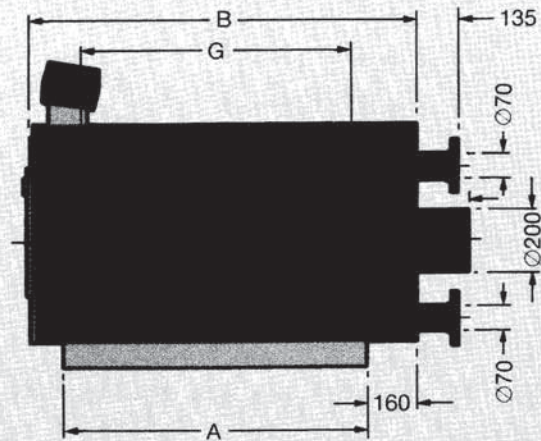

SIDE VIEW



END VIEW

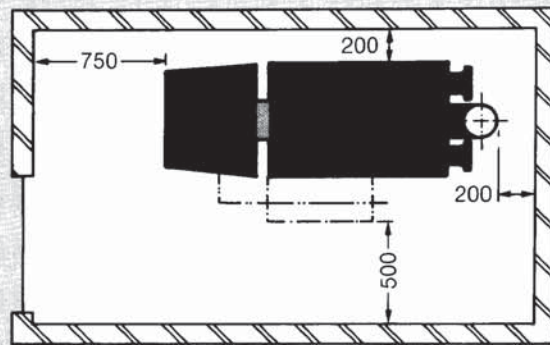

Recommended clearances for servicing

## Technical data

Number of Sections	Technical data		Dimensions mm			Water Resistance mm WG	Combustion Chamber Resistance	Water Content	Boiler Weight Dry	Minimum Flow Rate
	BTU/hr	kW	A	B	G	$\Delta t = 10^\circ\text{C}$	m/bar	Litres	kg	M <sup>3</sup> /hr
4	238,910	70	500	768	395	28	0.2	22	350	1.0
5	317,409	93	625	893	520	48	0.3	27	405	1.3
6	395,908	116	750	1018	645	76	0.5	32	460	1.6
7	477,820	140	875	1143	770	108	0.9	37	515	2.0
8	556,319	163	1000	1268	895	144	1.2	42	570	2.3
9	624,579	183	1125	1393	1020	184	1.6	47	625	2.6
10	689,426	202	1250	1518	1145	228	1.4	52	680	2.9
11	757,686	222	1375	1643	1270	272	1.8	57	725	3.2
12	825,946	242	1500	1768	1395	324	2.1	62	780	3.4
13	894,206	262	1625	1893	1520	380	2.5	67	835	3.7

Figures with 20% Excess Air.  
Flow and return counter flanges supplied 2½" for welding.

## Boiler section data

Section	Weight kg	Height mm	Width mm
Front	50	630	540
Middle	50	630	540
Back	48	630	540

# remeha OD 13B

## Technical information

Pressurized boiler

Heat output:  
59 - 256 kW



## CONTENTS

<b>Preface</b>	3	<b>8. Instrument panels</b>	10
<b>1. Description of the unit</b>	3	8.1 Equipment contents	10
1.1 General	3	8.2 Simple instrument panel On/Off	10
1.2 Burners	3	8.2.1 Lay out simple instrument panel	10
<b>2. Construction data</b>	3	8.2.2 Wiring diagram	11
2.1 General	3	simple instrument panel	11
2.2 Sections	3	8.3 Complete instrument panel High/Low	12
2.3 Casing	3	8.3.1 Lay out of the	12
<b>3. Technical data and dimensions</b>	4	complete instrument panel	12
<b>4. Output data</b>	5	8.3.2 Wiring diagram	13
4.1 Boiler efficiency	5	complete instrument panel	13
4.2 Combustion efficiency	5	<b>9. Commissioning</b>	14
<b>5. Application data</b>	6	9.1 Pressurized boiler with gas burner	14
5.1 L.P.H.W. version	6	9.1.1 Commissioning procedure	14
5.1.1 Water temperature	6	9.1.2 Putting out of operation	14
5.1.2 Water pressure	6	9.2 Pressurized boiler with oil burner	14
5.1.3 Flow rate	6	9.2.1 Commissioning procedure	14
5.1.4 Water treatment	6	9.2.2 Putting out of operation	14
5.2 Economisers	6	<b>10. Fault finding</b>	15
5.3 Flue gas discharge	6	10.1 High Limit thermostat lockout	15
5.4 Noise production	6	<b>11. Maintenance recommendations</b>	15
<b>6. Installation requirements</b>	7	11.1 General	15
6.1 Installation recommendations	7	11.2 Maintenance instructions	15
in the boiler house	7		
<b>7. Assembly guidelines and installation requirements</b>	8		
7.1 General	8		
7.2 Water connections	8		
7.3 Delivery in individual parts	8		
7.3.1 General	8		
7.3.2 Boiler assembly	8		
7.4 Delivery assembled (4 to 7 sections only)	8		

## PREFACE

These technical instructions contain useful and important information for the proper operation and maintenance of the central heating boiler, model remeha OD 13B. Further it contains important directions to prevent accidents and serious damage before putting it into service and during operation of the boiler, to permit as much as possible a safe and trouble-free operating. Read these instructions carefully before putting the boiler into service, familiarize yourself with its operation and control and strictly observe the directions given.

If you have any questions, or if you want more information about specific items relating to this boiler, please do not hesitate to contact us.

The data published in these technical instructions is based on the most recent information and is given subject to later revisions.

We reserve the right to modify the construction and/or design of our products at any moment, without obligation to update earlier supplies accordingly.

## 1. DESCRIPTION OF THE UNIT

### 1.1 General

High efficiency pressurized boiler, suitable for use with natural gas and light oil, by means of a pressure jet burner. Also available with ECO (for natural gas only). Up to 141 kW the OD 13B can be delivered assembled (except for casing and instrument panel).

The boiler meets the requirements of the CE regulations at the following directives:

- Gas appliance directive no. 90/396/EEC
- Electrical low voltage directive no. 73/23/EEC
- Machinery directive no. 89/392/EEC
- E.M.C. directive no. 89/336/EEC
- Efficiency directive 92/42/EEC.

Classification type for evacuation of the combustion products: B23.

### 1.2 Burners

In principle all pressure jet burners are suitable, subject to prior adjustment to the boiler capacity and boiler construction. The individual boiler satisfies inspection requirement for central heating boilers.

## 2. CONSTRUCTION DATA

### 2.1 General

The boiler block consists of cast iron sections which are assembled by means of tapered nipples. The boiler is designed on the basis of the three pass principle. The boiler block is insulated with a 80 mm thick layer of glass wool.

### 2.2 Sections

The sections are made of pearlitic cast iron.

Weights and measures of the sections:

Front sections: 50 kg H x W = 630 x 540 mm  
Intermediate section: 50 kg H x W = 630 x 540 mm  
Rear section: 48 kg H x W = 630 x 540 mm

### 2.3 Casing

Steel casing, finished with a high-quality insulation. The front door is suitable for left or right opening as desired.

3. TECHNICAL DATA AND DIMENSIONS

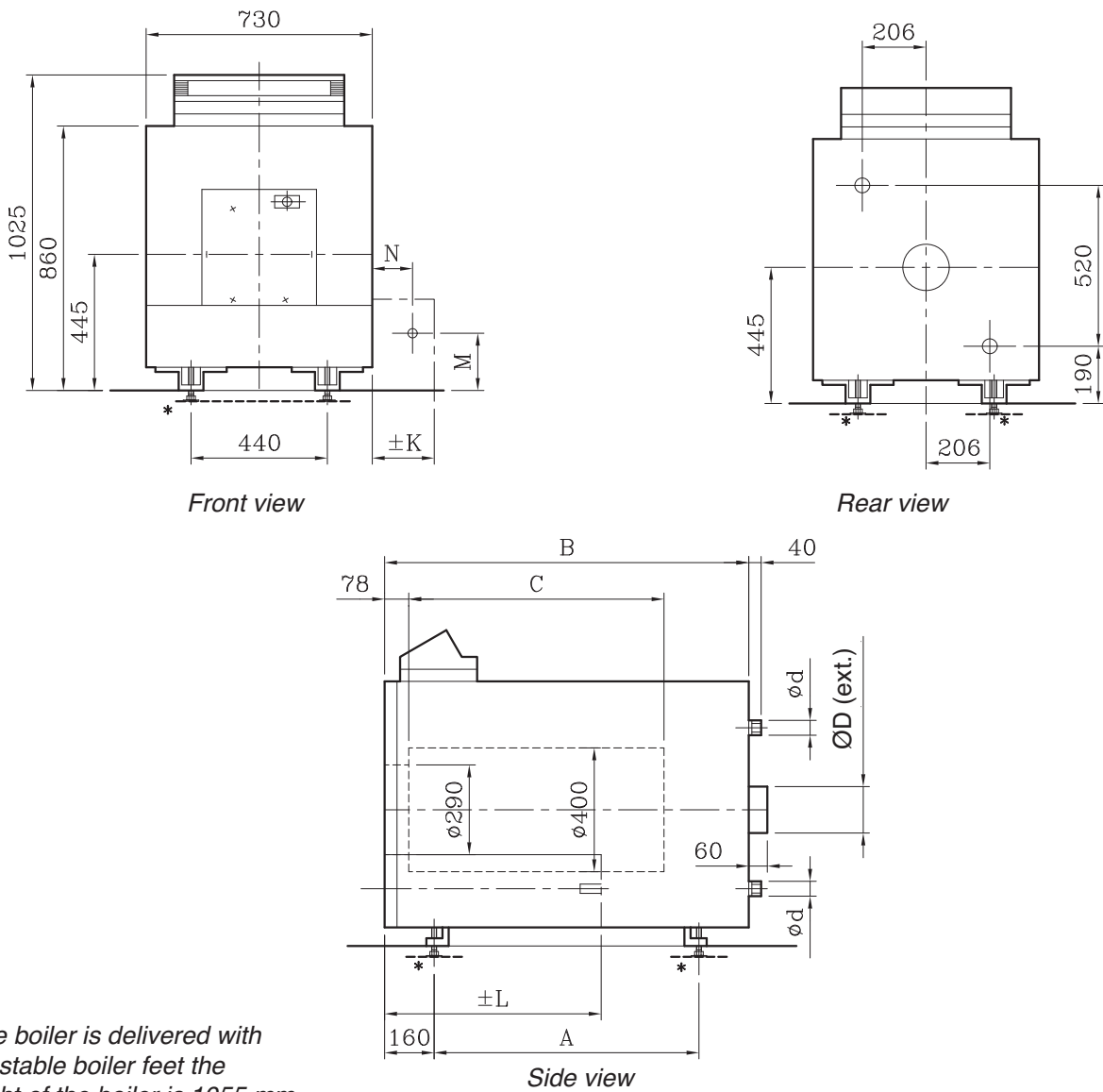

Fig. 01 View figures

No. of sections	Output	Input GCV	Combustion chamber resistance <sup>1)</sup>	Combustion gas side content	Water resistance		Water content	Weight (dry) approx.	Sizes				
					$\Delta t = 20^{\circ}\text{C}$	$\Delta t = 10^{\circ}\text{C}$			A	B	C	$\phi D$	$\phi d$
	kW	kW	mbar	m <sup>3</sup>	mbar	mbar	liters	kg	mm	mm	mm	mm	mm
4	59	73	0.1	0.08	2	9	24	365	484	802	450	150	1 1/2"
5	93	114	0.3	0.11	5	22	29	425	608	927	575	150	1 1/2"
6	117	143	0.6	0.13	8	34	34	485	732	1052	700	150	1 1/2"
7	141	172	1.0	0.16	12	48	39	545	856	1177	825	150	1 1/2"
8	165	201	1.2	0.18	17	67	44	605	980	1294	950	200	2"
9	184	224	1.6	0.21	21	84	49	665	1104	1419	1075	200	2"
10	206	250	1.4	0.23	26	103	54	725	1228	1544	1200	200	2"
11	229	278	1.8	0.26	32	127	59	775	1352	1669	1325	200	2"
12	256	309	2.1	0.28	39	158	64	835	1476	1794	1450	200	2"

<sup>1)</sup> Determined with 20 % excess air.

#### 4. OUTPUT DATA

##### 4.1 Boiler efficiency

Upto 82.6 % at GCV (91.7% at NCV) at full load and upto 84.0% at GCV (93.2% at NCV), at part load.  
Average water temperature 70°C (80/60°C).

##### 4.2 Combustion efficiency

Upto 83.8% at GCV (93.0% at NCV) at full load and upto 86.0% at GCV (95.5% at NCV) at part load.



## 5. APPLICATION DATA

### 5.1 L.P.H.W. version

#### 5.1.1 Water temperature

Maximum water temperature is 110°C.

The minimum acceptable return water temperature is, for gas fired boilers 45°C and for oil fired boilers 40°C, at a flow rate corresponding to a  $\Delta t$  of 20°C at nominal heat output.

#### 5.1.2 Water pressure

Maximum pressure 6 bar.

The boiler is suitable for open and sealed systems up to a maximum pressure of 6 bar and a minimum pressure of 0.8 bar. Installation of the boiler in rooftop or in basement boiler room is possible.

#### 5.1.3 Flow rate

The minimum flow rate through the boiler is obtained from the following formula:

$$\frac{\text{nominal heat output (kW)}}{70} = \text{m}^3/\text{h}$$

This minimum flow must be maintained for 5 minutes after the burner stops firing to avoid high temperature shut - down due to residual heat gain.

Due to the design and manufacture of the boiler no specific minimum water flow requirement exists other than for over-temperature protection.

#### 5.1.4 Water treatment

Under normal conditions water treatment is not required (see our leaflet on water quality recommendations).

### 5.2 Economisers

ECO's can be delivered upon request (for natural gas only).

### 5.3 Flue gas discharge

For the discharge of the flue gases, chimney draught is not required.

Tests have shown that very good combustion results are obtained with zero draught at the boiler outlet.

### 5.4 Noise production

The noise level taken at a distance of 1 m around the boiler is approximately 70 to 90 dBA. The noise level at the chimney outlet will, depending on load, type of burner and chimney situation, vary from 70 to 90 dBA, taken at a distance of 1 m from the outlet. If this noise production give rise to problems in the immediate vicinity, then noise-reducing or absorbing measures should be taken.

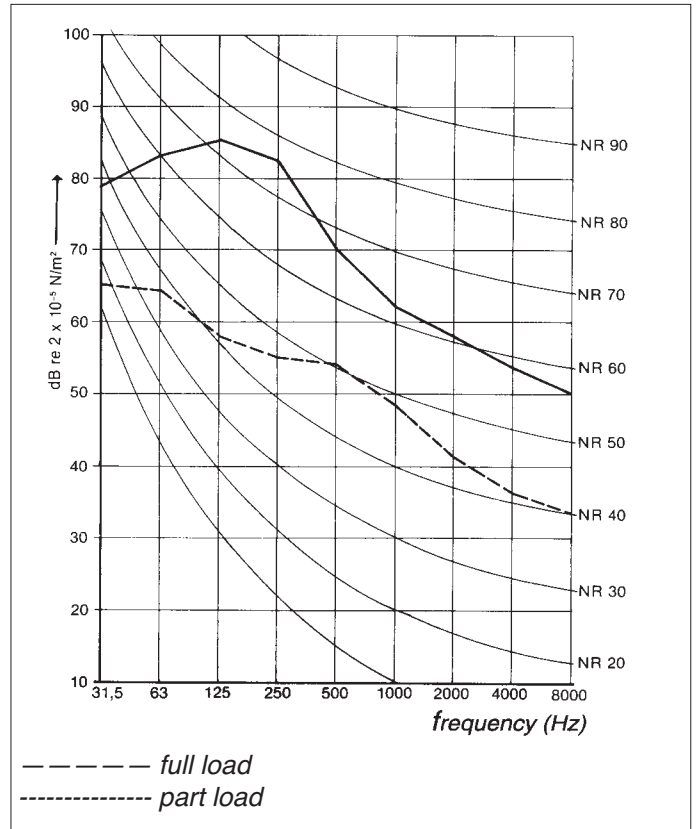

Fig. 02 Noise observation OD 13B with burner without noise silencer.

The values that have been taken are averages obtained from various measurements carried out at a distance of approximately 1 m around the boiler and at a height of approximately 1 m.

**6. INSTALLATION REQUIREMENTS**

**6.1 Installation recommendations in the boiler house**

The necessary minimum installation space of the boiler can be seen from figure 03.

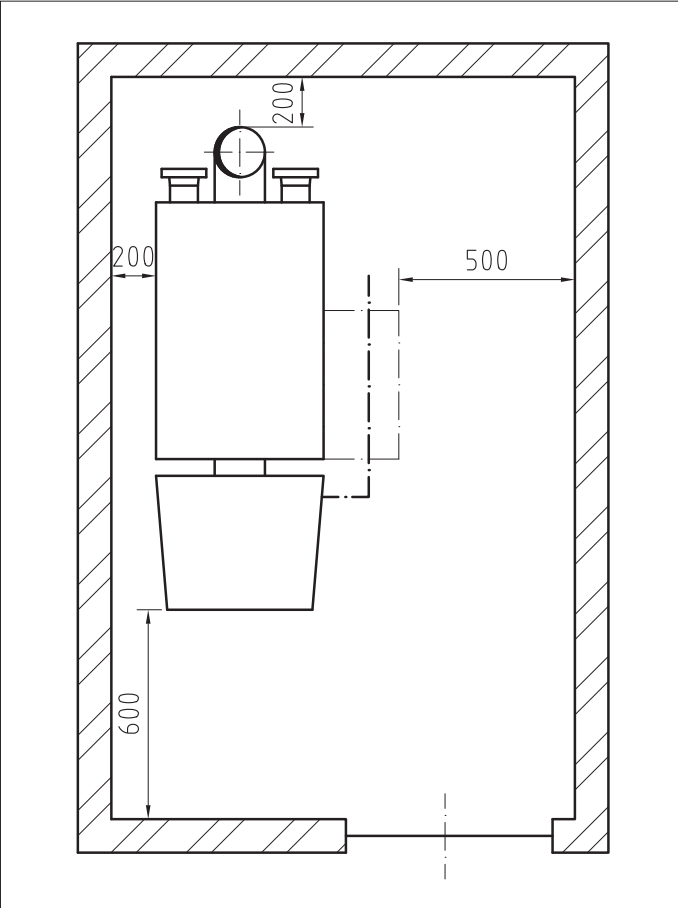

*Fig. 03 Installation recommendations in the boiler house*

## 7. ASSEMBLY GUIDELINES AND INSTALLATION REQUIREMENTS

### 7.1 General

The remeha boilers OD 13B - 4 to 7 sections can be delivered in individual parts or assembled. The remeha boilers OD 13B - 8 to 12 sections are being delivered in individual parts.

### 7.2 Water connections

The water connections are at the rear of the boiler. The flow and return connections consist of thread male connections : 4 - 7 sections  $1\frac{1}{2}$ "  
8 - 12 sections 2"

Flange connections in accordance with DIN 2633 can be delivered on request ( $\varnothing$  70 mm ID)

The top flange at the front of the boiler is provided with 3 x  $R\frac{1}{2}$ " threaded holes for the fitting of the thermostat pockets. The return connection is provided with a  $R\frac{3}{4}$ " threaded hole in which a drain off cock is fitted.

### 7.3 Delivery in individual parts

#### 7.3.1 General

The sizes of the parts are such that they all can enter the boiler house through a normal entrance.

The casing and equipment parts are delivered in packaged units. If necessary, the boiler can be put into operation without casing. The casing can be added at a later stage without dismantling the water connections. On request the boiler can be delivered with adjustable boiler feet.

#### 7.3.2 Boiler assembly

Assembly and installation of a boiler delivered in individual parts may only take place by a recognized and approved engineer and in accordance with the assembly manual. Local regulations laid down by the relevant authorities must be adhered to.

### 7.4 Delivery assembled (4 to 7 sections only)

The boiler is delivered completely assembled in a crate and on a pallet. Just the casings and the instrument panel are delivered separate in package units in the crate. The boiler is delivered with adjustable boiler feet (figure 04). By unscrewing the boiler feet, the boiler lifts itself up from the pallet. The pallet can now be dismantled and taken away (figure 05). Now the boiler can be adjusted horizontal and at the right height (figure 06).

After the installation of the boiler, the casings and the instrument panel can be fitted (figure 07).

If necessary, the boiler can be put into operation without casing. The casing can be added at a later stage without disconnecting the water connections.

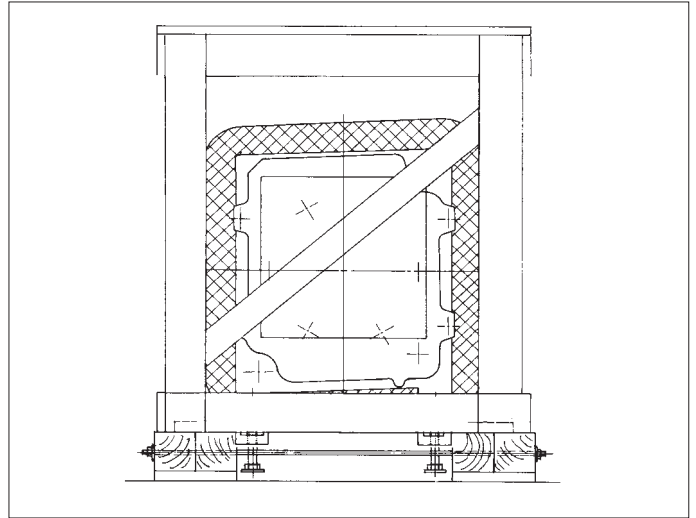

Fig. 04 The boiler completely assembled in a crate and on a pallet.

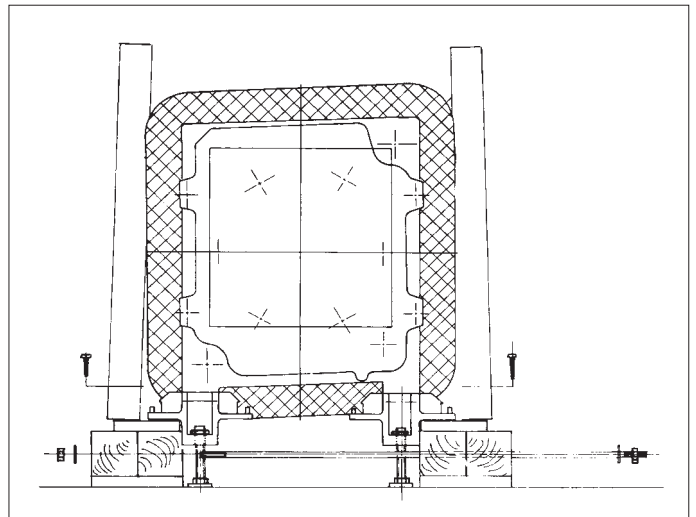

Fig. 05 The pallet dismantled and taken away

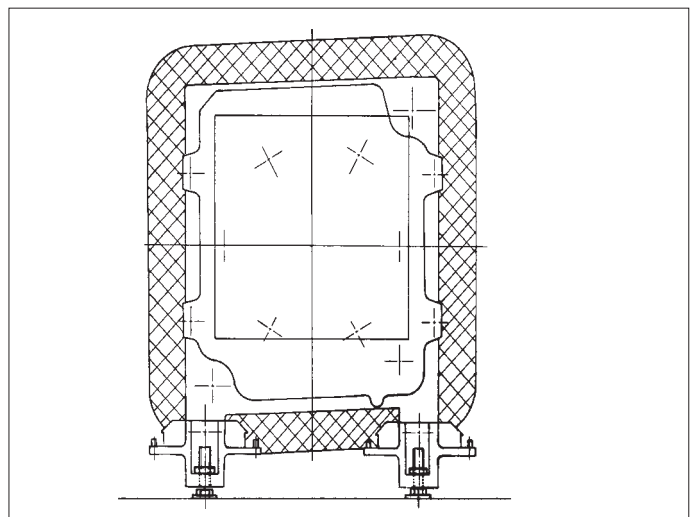

Fig. 06 The boiler adjusted horizontal and at the right height

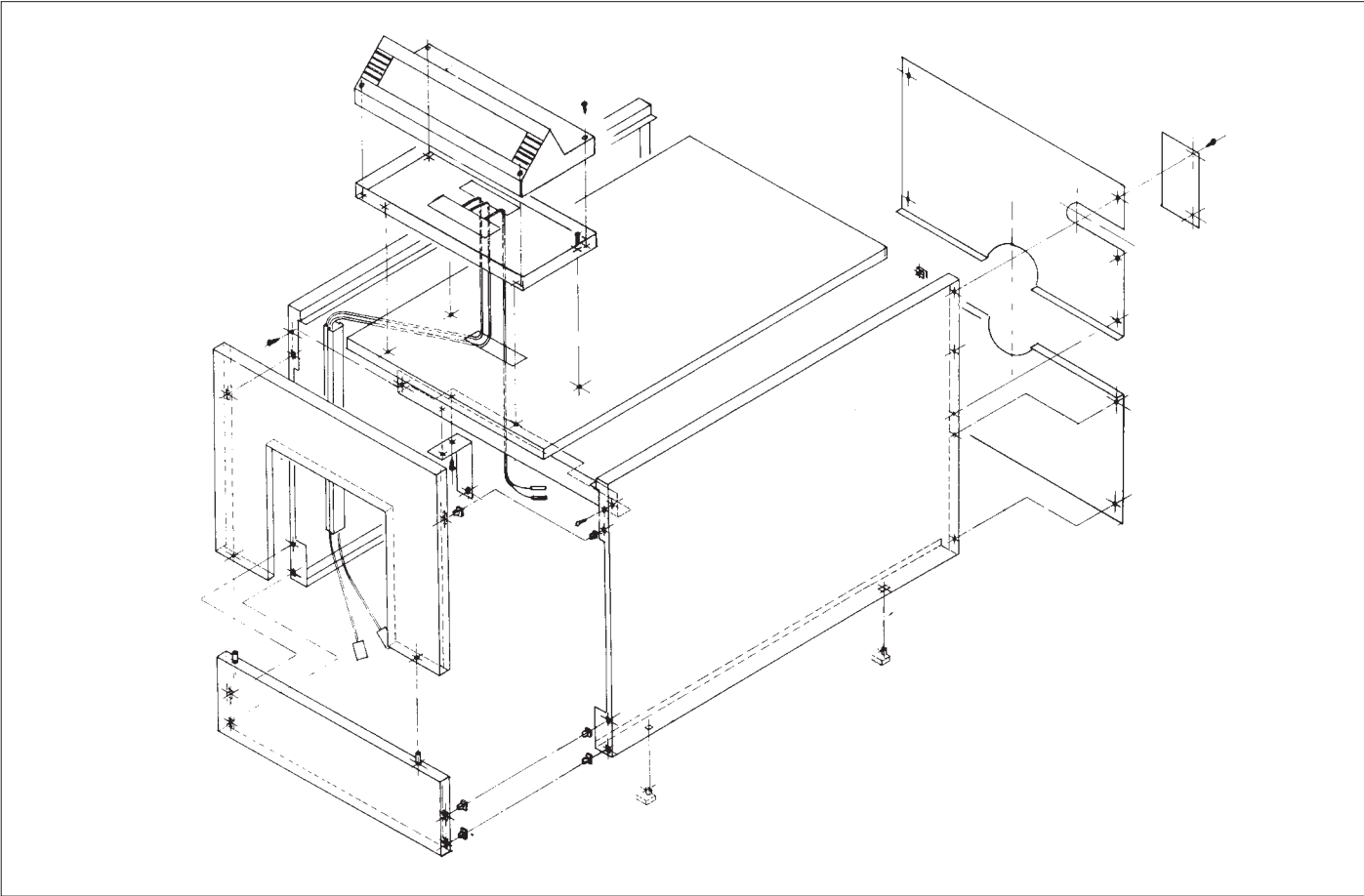

Fig. 07 Mounting casings and the instrument panel.

## 8. INSTRUMENT PANELS

### 8.1 Equipment contents

The instrument panel can be delivered in two models :

- Simple instrument panel On/Off
- Complete instrument panel High/Low

The panels contain all the necessary control and measuring instruments required to control the boiler.

All connections are pre-wired and fitted with plugs.

The connections to the simple instrument panel have to be made on a terminal strip.

The capillaries and sensor wires, which come from the control panel, are placed in the instrument pockets that are fitted at the front of the boiler.

### 8.2 Simple instrument panel On/Off

#### 8.2.1 Lay out simple instrument panel

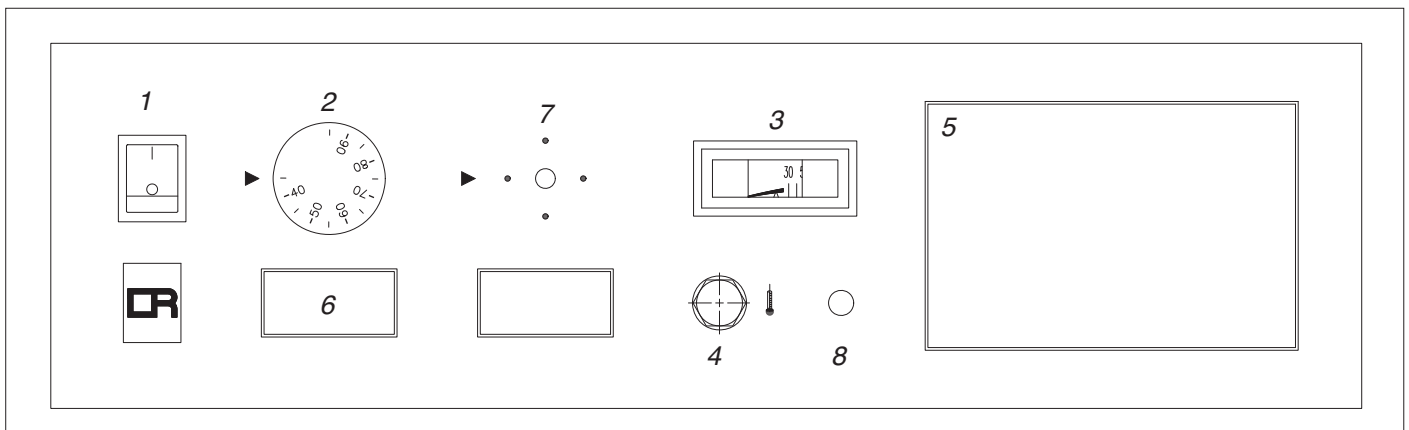

Fig. 08 Layout of the simple instrument panel

- |   |   |
|---|---|
| <ol style="list-style-type: none"> <li>1. Operating switch (On/Off)</li> <li>2. Control thermostat<br/>Setting between 0°C - 90°C</li> <li>3. Analogue thermometer water temperature</li> <li>4. High limit thermostat 110°C (locking)</li> </ol> | <ol style="list-style-type: none"> <li>5. Option for weather compensator</li> <li>6. Option for hour counter</li> <li>7. Not used by this panel</li> <li>8. Option for central warning light</li> </ol> |
|---|---|

### 8.2.2 Wiring diagram simple instrument panel

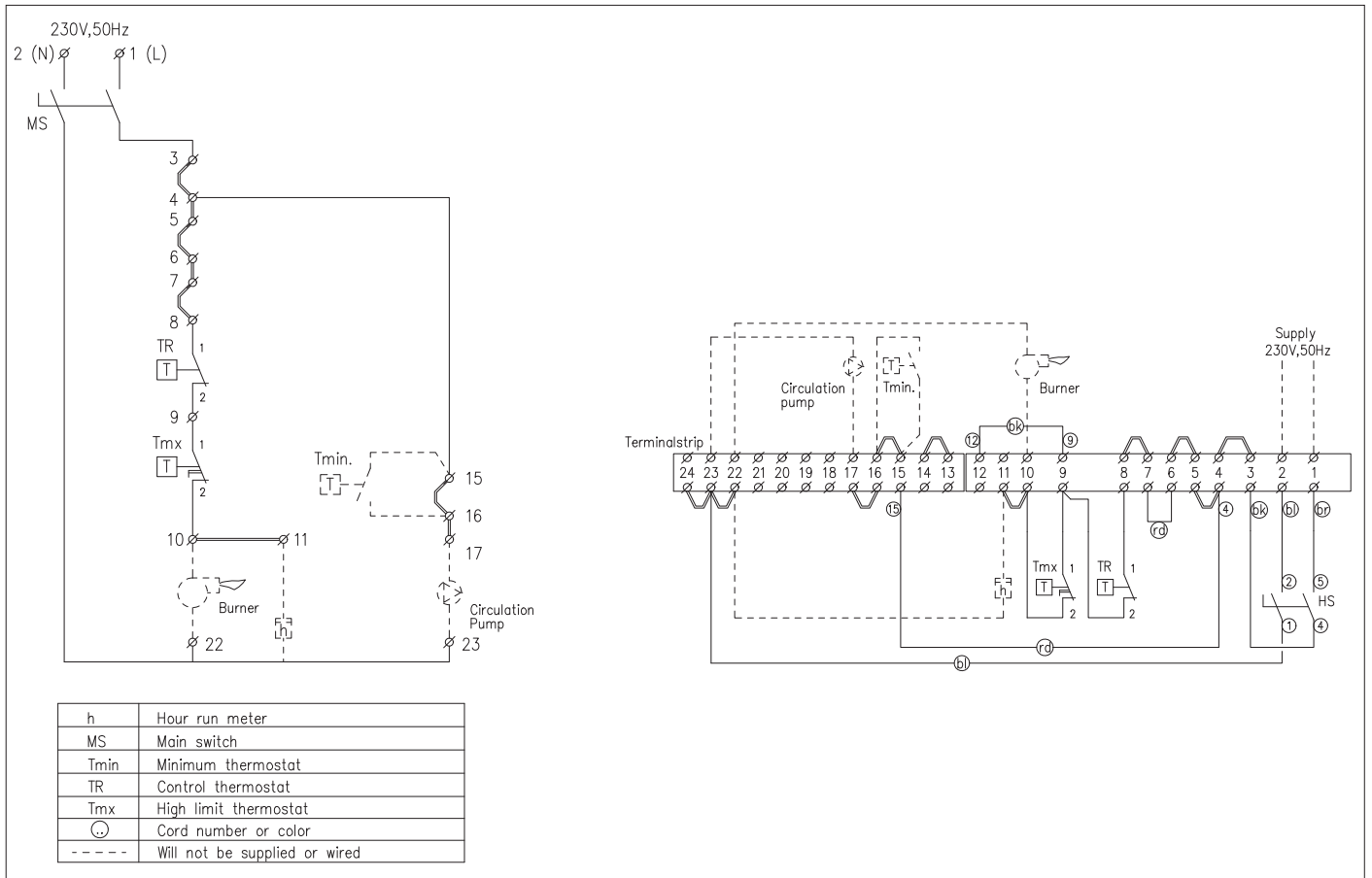

Fig. 09 Wiring diagram simple instrument panel

## 8.3 Complete instrument panel High/Low

### 8.3.1 Lay out of the complete instrument panel

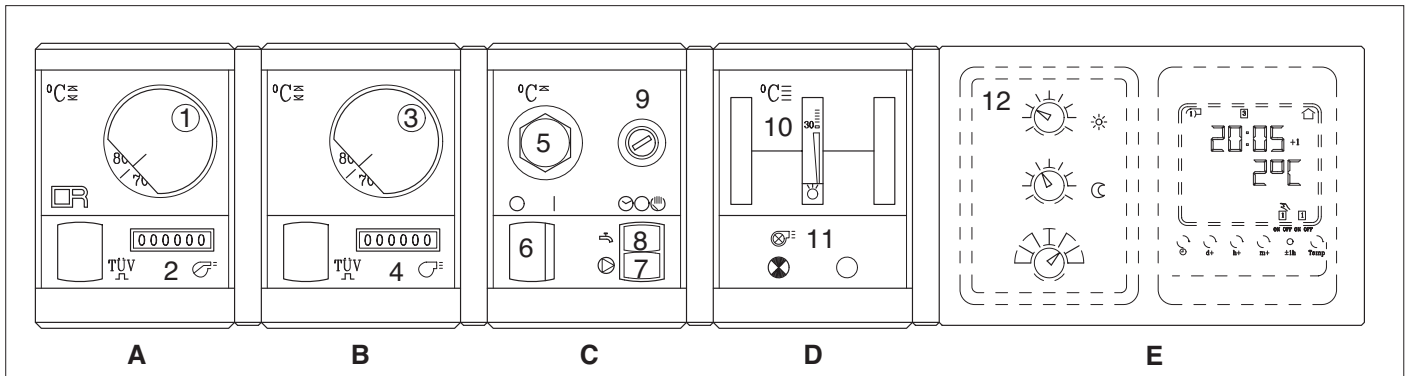

Fig. 10 Lay out of the complete instrument panel

The complete instrument panel consists of modules.  
The modules contain:

#### Module A

1. Control thermostat  
Setting between 35°C - 95°C.
2. Hour counter part load.

#### Module B

3. High/Low thermostat  
Setting between 35°C - 95°C.
4. Hour counter full load.

#### Module C

5. High limit thermostat 110°C (locking).
6. Operating switch (On/Off) with optical display.
7. Switch for circulating pump  
Manual/Off/Automatic.
8. Switch for domestic hot water storage pump  
Manual/Off/Automatic.
9. Fuse 6.3 A MT.

#### Module D

10. Analogue thermometer water temperature.
11. Central warning light.

#### Module E

12. Option for *rematic*<sup>®</sup> weather compensator.

Fig. 11 Wiring diagram complete instrument panel

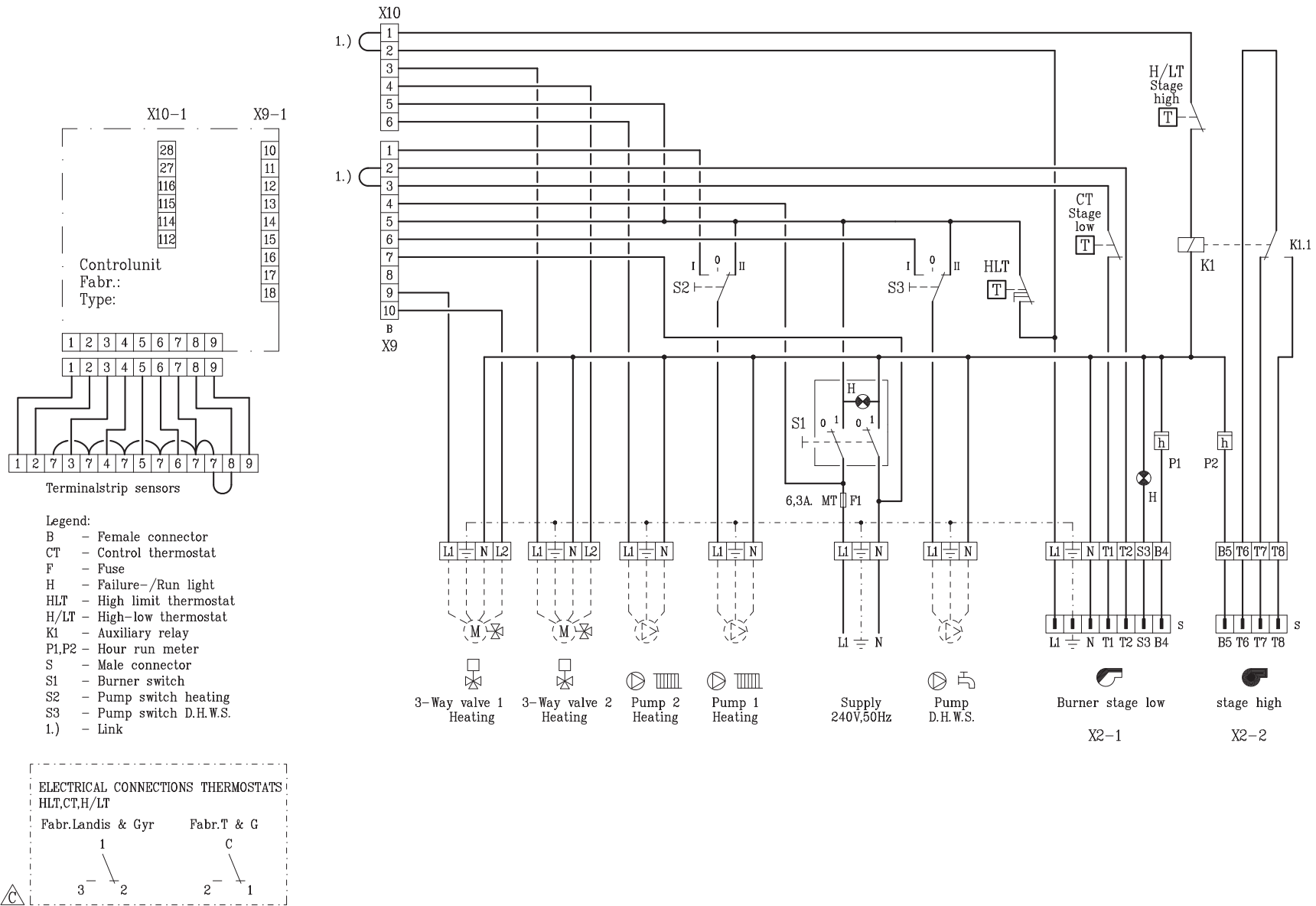



## 9. COMMISSIONING

### 9.1 Pressurized boiler with gas burner

#### 9.1.1 Commissioning procedure

If the boiler is to be put into operation again following a period of non-use, then the following procedure must be carried out :

- a. Open the main gas cock.
- b. Switch the weather-compensator (if fitted) over to manual operation.
- c. Turn the thermostats to their highest setting.
- d. Switch on the circulation pump.
- e. Switch on the main switch.
- f. Switch on the operation switch in the instrument panel.
- g. Consult burner manufacturer commissioning details.

#### Warning

If the instrument panel is fitted with a weather-compensator, set the programm switch to 'manual' position. In the event that either a circulation and / or a Hot Domestic Water storage pump are connected to the boiler control, set both pump switches in the 'manual' position. (These two switches are only fitted in the complete instrument panel next to the operating switch.) The following will now take place: the gas burner fan will start running so that during the purging time the combustion chamber will be ventilated with fully opened air damper. Then the air damper will go into start position. Ignition flame lights up and is checked. Then the control box gives the all clear signal for the burner to switch over to full load.

#### 9.1.2 Putting out of operation

It is sufficient to switch off the operation switch on the instrument panel. It is recommended that in the event of work being carried out on the burner, the main gas cock is shut.

### 9.2 Pressurized boiler with oil burner

#### 9.2.1 Commissioning procedure

If the boiler is to be put into operation again following a period of non-use, then the following procedure must be carried out :

- a. Open the main oil cock.
- b. Switch the weather-compensator (if fitted) over to manual operation.
- c. Turn the thermostat to their highest setting.
- d. Switch on the circulation pump.
- e. Switch on the main switch.
- f. Switch on the operation switch in the control panel.
- g. Consult burner manufacturer commissioning details.

#### Warning

If the instrument panel is fitted with a weather-compensator, set the programm switch to 'manual' position. In the event that either a circulation and / or a Hot Domestic Water storage pump are connected to the boiler control, set both pump switches in the 'manual' position. (These two switches are only fitted in the complete control panel next to the operating switch). The following will now take place: the oil burner fan will start running so that during the purging time the combustion chamber will be ventilated with fully opened air damper. Then the air damper will go into start position. Ignition flame lights up and is checked. Then the control box gives the all clear signal for the burner to switch over to full load.

#### 9.2.2 Putting out of operation

It is sufficient to switch off the operation switch on the instrument panel. It is recommended that in the event of work being carried out on the burner, the main oil valve is shut.

## 10. FAULT FINDING

### 10.1 High Limit thermostat lockout

- Check the water circulation (circulation pump). Reset the High Limit thermostat (Reset button is on the instrument panel under the cover cap of the High Limit thermostat).
- If the circulation pump is connected by the instrument panel, check if the pump switch is in 'manual' position. (Never put this switch in 'clock' position, if a weather compensator is not fitted).
- Advise the installer in the event of continued lock outs.

## 11. MAINTENANCE RECOMMENDATIONS

### 11.1 General

Depending on the operational conditions, the block and the burner must be checked and cleaned one or more times a year.

### 11.2 Maintenance instructions

- Cleaning of the boiler
  - Put boiler out of operation.
  - Open the front door, if necessary after dismantling the burner.
  - Remove the retarders (only for the 4 - 9 sections).
  - Clean the combustion chamber and flue passes using a suitable brush.
  - Clean the removed retarders (4 - 9 sections).
  - Remove the rear panel of the boiler and remove the cleaning cover (underneath the smoke box).
- Vacuum clean the boiler and the combustion gas chamber.
- Renew the front door seals after cleaning the boiler.
- Re-assemble the removed parts and close the front door.
- Re-assembled the burner (if dismantled).
- Check the boiler combustion side for leakage.
- Check the equipment for proper functioning and if necessary re-adjust the gas control and safety equipment.
- Check combustion by means of combustion gas analyses.
- Check the water connections.



**Broag Ltd.**

**Head Office**

Remeha House,  
Molly Millars Lane,  
Wokingham,  
Berkshire RG41 2QP  
Tel. 0118 9783434  
Fax 0118 9786977

**Branch Office**

Unit 3, Kestrel Close,  
Quarry Hill Ind. Estate,  
Ilkeston,  
Derbyshire DE7 4RD  
Tel. 0115 9440778  
Fax 0115 9440588

**© Copyright**

All technical and technological information contained in these technical instructions, as well as any drawings and technical descriptions furnished by us remain our property and shall not be multiplied without our prior consent in writing.

# remeha OD 14B

## Technical information

Pressurized boiler

Heat output:  
278 - 709 kW



## CONTENTS

<b>Preface</b>	3	<b>7. Assembly guidelines and installation requirements</b>	7
<b>1. Description of the unit</b>	3	7.1 General	7
1.1 General	3	7.2 Boiler assembly	7
1.2 Burners	3	7.3 Water connections	7
<b>2. Construction data</b>	3	<b>8. Instrument panel</b>	8
2.1 General	3	8.1 Equipment contents	8
2.2 Sections	3	<b>9. Electrical installation requirements</b>	9
2.3 Casing	3	9.1 Wiring diagram instrument panel	9
<b>3. Technical data and dimensions</b>	4	<b>10. Commissioning</b>	10
<b>4. Output data</b>	5	10.1 Pressurized boiler with gas burner	10
4.1 Boiler efficiency	5	10.1.1 Commissioning procedure	10
4.2 Combustion efficiency	5	10.1.2 Putting out of operation	10
<b>5. Application data</b>	6	10.2 Pressurized boiler with oil burner	10
5.1 Hot water version	6	10.2.1 Commissioning procedure	10
5.1.1 Water temperature	6	10.2.2 Putting out of operation	10
5.1.2 Water pressure	6	<b>11. Fault finding</b>	11
5.1.3 Flow rate	6	11.1 High Limit thermostat lockout	11
5.1.4 Water treatment	6	<b>12. Maintenance recommendations</b>	11
5.2 Noise production	6	12.1 General	11
5.3 Economisers	6	12.2 Maintenance instructions	11
5.4 Flue gas discharge	6		
<b>6. Installation requirements</b>	7		
6.1 Installation recommendations in the boiler house	7		
6.2 Base details	7		

## PREFACE

These technical instructions contain useful and important information for the proper operation and maintenance of the Remeha central heating boiler, model OD 14B. Further it contains important directions to prevent accidents and serious damage before putting it into service and during operation of the boiler, to permit as much as possible safe and trouble-free operation. Read these instructions carefully before putting the boiler into service, familiarize yourself with its operation and

control and strictly observe the directions given. If you have any questions, or if you want more information about specific subjects relating to this boiler, please do not hesitate to contact us. The data published in these technical instructions is based on the most recent information and is given subject to later revisions. We reserve the right to modify the construction and/or design of our products at any moment, without obligation to update earlier supplies accordingly.

## 1. DESCRIPTION OF THE UNIT

### 1.1 General

High efficiency pressurized boiler, suitable for use with natural gas and light oil, by means of a pressure jet burner.

Also available with ECO (for natural gas only).

The boiler meets the requirements of the CE regulations at the following directives:

- Gas appliance directive no. 90/396/EEC
- Electrical low voltage directive no. 73/23/EEC
- Machinery directive no. 89/392/EEC
- E.M.C. directive no. 89/336/EEC
- Efficiency directive 92/42/EEC.

Classification type for evacuation of the combustion products: B23.

### 1.2 Burners

In principle all pressure jet burners are suitable, subject to prior adjustment to the boiler capacity and boiler construction. The individual boiler satisfies inspection requirement for central heating boilers.

## 2. CONSTRUCTION DATA

### 2.1 General

The boiler block consists of cast iron sections which are assembled by means of tapered nipples. The boiler is designed on the basis of the triple pass principle. The boiler block is insulated with a 100 mm thick layer of glass wool.

### 2.2 Sections

The sections are made of pearlitic cast iron.

Weights and measures of the sections:

Front section	: 93 kg H x W 1026 x 630 mm
Intermediate section	: 106 kg H x W 1026 x 630 mm
Rear section	: 114 kg H x W 1026 x 630 mm

### 2.3 Casing

Enamelled steel casing, finished with a high-quality insulation.

The front door is suitable for left or right opening as desired.

## 3. TECHNICAL DATA AND DIMENSIONS

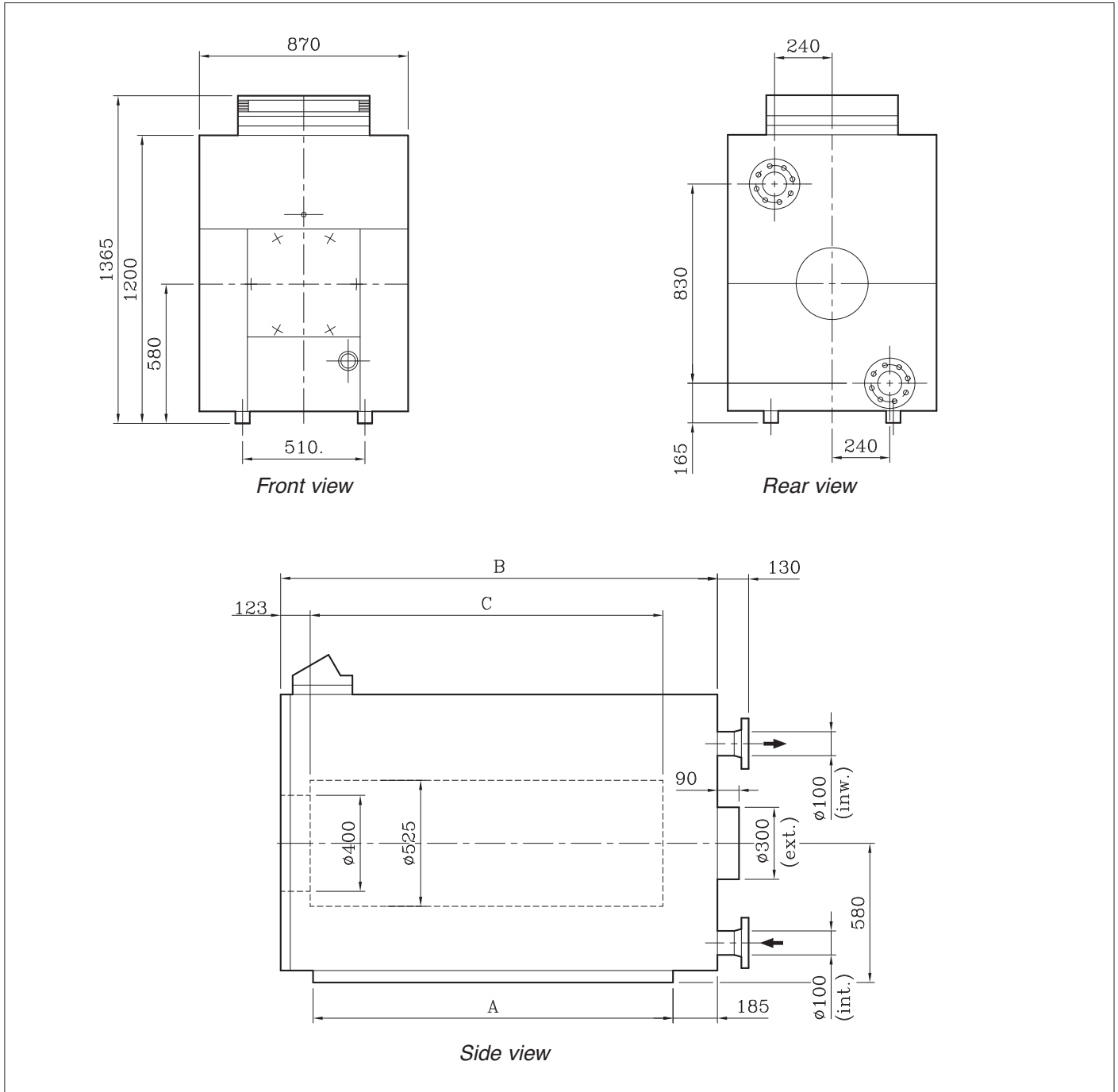

Fig. 01 Dimensions of the remeha OD 14B

No. of sections	Output kW	Input GCV kW	Combustion chamber resistance* mbar	Combustion gas side contents m <sup>3</sup>	Water resistance		Water contents liters	Weight (dry) approx. kg	Flue gas flow rate kg/h	Sizes		
					$\Delta t = 20^{\circ}\text{C}$ mbar	$\Delta t = 10^{\circ}\text{C}$ mbar				A mm	B mm	C mm
8	278	345	1,1	0,43	11	45	146	1040	505	1200	1520	1170
9	331	410	1,4	0,48	14	56	163	1145	599	1350	1670	1320
10	383	471	1,9	0,53	18	72	180	1250	690	1500	1820	1470
11	437	538	2,4	0,58	22	88	197	1355	785	1650	1970	1620
12	491	603	3,4	0,63	27	108	214	1460	879	1800	2120	1770
13	543	665	4,0	0,68	34	136	231	1565	952	1950	2270	1920
14	596	728	4,5	0,73	42	168	248	1670	1063	2100	2410	2070
15	651	794	4,8	0,78	50	200	265	1775	1158	2250	2560	2220
16	709	862	5,0	0,83	57	228	282	1880	1257	2400	2710	2370

\* Determined with 20% excess air

#### 4. OUTPUT DATA

##### 4.1 Boiler efficiency

Up to 82.6% at GCV (91.7% at NCV) at full load and approx. 84.1% at GCV (93.4% at NCV), at part load. Average water temperature 70°C (80/60°C).

##### 4.2 Combustion efficiency

Up to 83.1% at GCV (chimney loss 16.9%) at full and 85.1% at GCV at part load.



## 5. APPLICATION DATA

### 5.1 Hot water version

#### 5.1.1 Water temperature

Maximum water temperature is 110°C.

The minimum acceptable return water temperature is, for gas fired boilers 45°C and for oil fired boilers 40°C, at a flow rate corresponding to a  $\Delta t$  of 20°C at nominal heat input.

#### 5.1.2 Water pressure

Maximum pressure 6 bar.

The boiler is suitable for open and sealed systems up to a maximum pressure of 6 bar and a minimum pressure of 0.8 bar. Installation of the boiler on rooftop or in basement is possible.

#### 5.1.3 Flow rate

The minimum flow rate through the boiler is obtained from the following formula:

$$\frac{\text{nominal heat output (kW)}}{70} = \text{m}^3/\text{h}$$

This minimum flow must be maintained for 5 minutes after the burner stops firing to avoid high temperature shut-down due to residual heat gain.

Due to the design and manufacture of the boiler no specific minimum water flow requirement exists other than for over temperature protection.

#### 5.1.4 Water treatment

Water treatment of all systems, but in particular open vented systems used with the remeha OD 14B, is considered necessary good practice in order to:

- Avoid metallic corrosion within the system
- Avoid sludge and scale formation
- Reduce to a minimum the risk of microbiological contamination of the system
- Minimise chemical action and changes which take place over a period of time when system water is untreated.

Suitable chemicals and the extend of treatment should be discussed with specialist manufactures prior to any work commencing. (See also our leaflet on waterquality recommendations).

### 5.2 Noise production

The noise level taken at a distance of 1 m around the boiler is approx. 70 to 90 dBA. The noise level at the chimney outlet will, depending on load, type of burner and chimney situation, vary from 70 to 90 dBA, taken at a distance of 1 m from the outlet. If this noise production gives rise to problems in the immediate vicinity, then noise reducing or absorbing measures should be taken.

### Noise measurement remeha OD 14B

remeha OD 14B with burner without noise silencer.

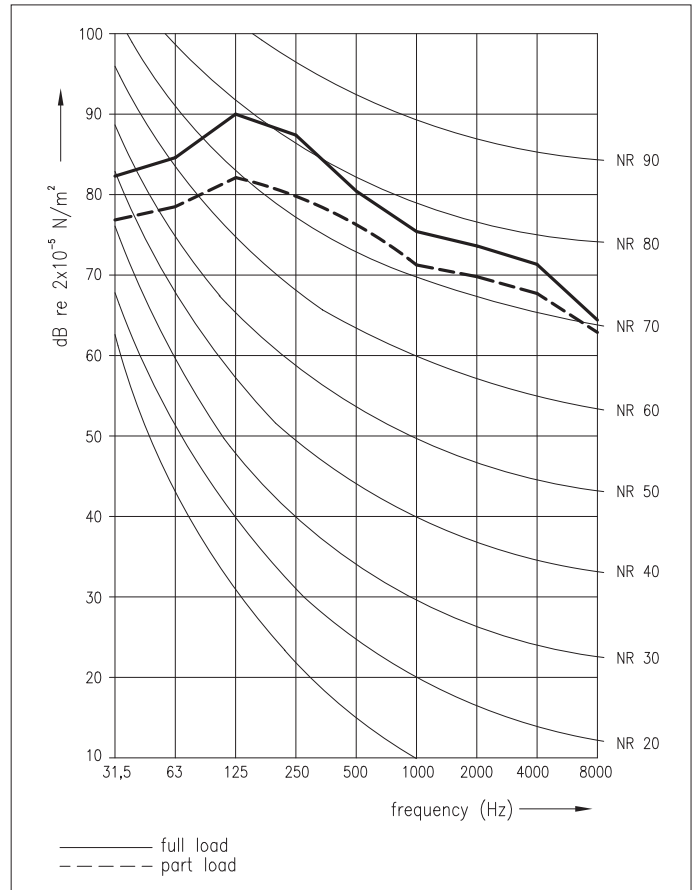

Fig. 02 Noise measurement remeha OD 14B

The values that have been taken are averages obtained from various measurements carried out at a distance of approx. 1 m around the boiler and at a height of approx. 1 m.

### 5.3 Economisers

ECO's can be delivered upon request (for natural gas only).

### 5.4 Flue gas discharge

For the discharge of the flue gasses, chimney draught is not required. Tests have shown that very good combustion results are obtained with zero draught at the boiler outlet.

## 6. INSTALLATION REQUIREMENTS

### 6.1 Installation recommendations in the boiler house

The necessary minimum installation space of the boiler can be seen from the figure below.

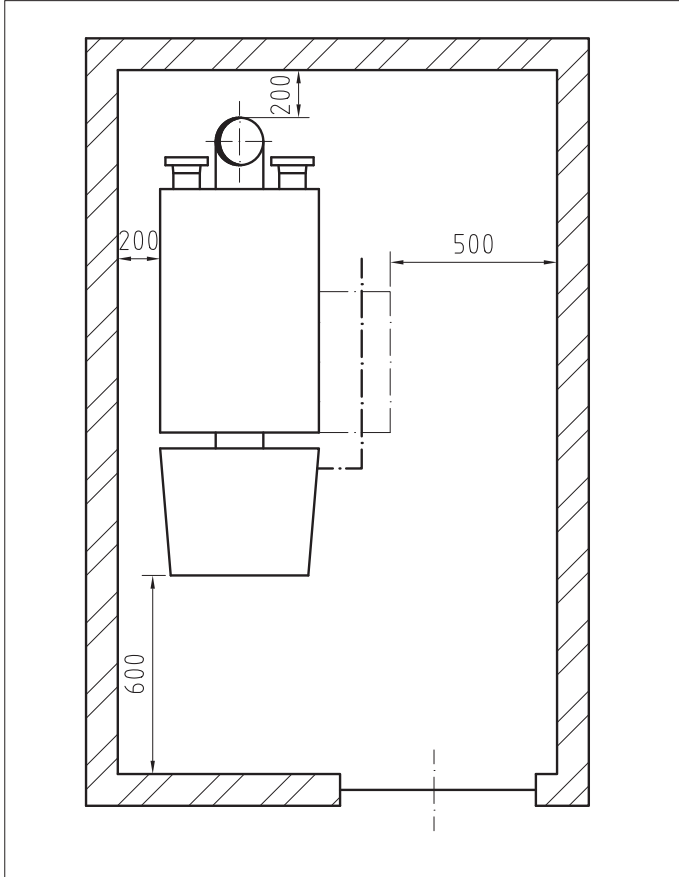

Fig. 03 Installation space of the remeha OD 14B

### 6.2 Base details

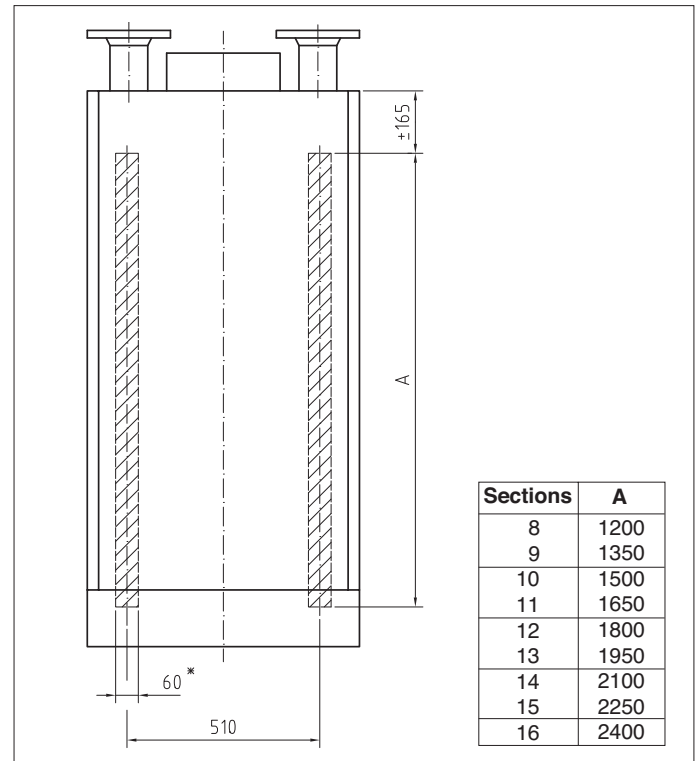

Fig. 04 Base details

\* 50 mm with vibration damper

## 7. ASSEMBLY GUIDELINES AND INSTALLATION REQUIREMENTS

### 7.1 General

The remeha OD 14B boiler is delivered in individual sections. The sizes are such that all parts can enter the boiler house through a normal door entrance.

The casing and equipment parts are delivered in packaged units. If necessary, the boiler can be put into operation without casing. The casing can be added at a later stage without disconnecting the water connections.

### 7.2 Boiler assembly

Assembly and installation of the boiler may only take place by a recognised and approved engineer and in accordance with the assembly manual. Local regulations laid down by the relevant authorities must be adhered to.

### 7.3 Water connections

The water connections are at the rear of the boiler. The flow and return connections consist of flanged connections in accordance with DIN 2633.

The top flange at the front of the boiler is provided with 3 x R1/2" threaded holes for the fitting of the thermostat pockets. The return connection is provided with a R 3/4" threaded hole in which a drain off cock is fitted.

## 8. INSTRUMENT PANEL

### 8.1 Equipment contents

The instrument panel consists of modules. The modules contain all the necessary control and measuring instruments required to regulate the boiler. All connections are pre-wired and fitted with plugs. The capillaries and sensor wires, which come from the control panel, are placed in the immersion pockets that are fitted at the front of the boiler.

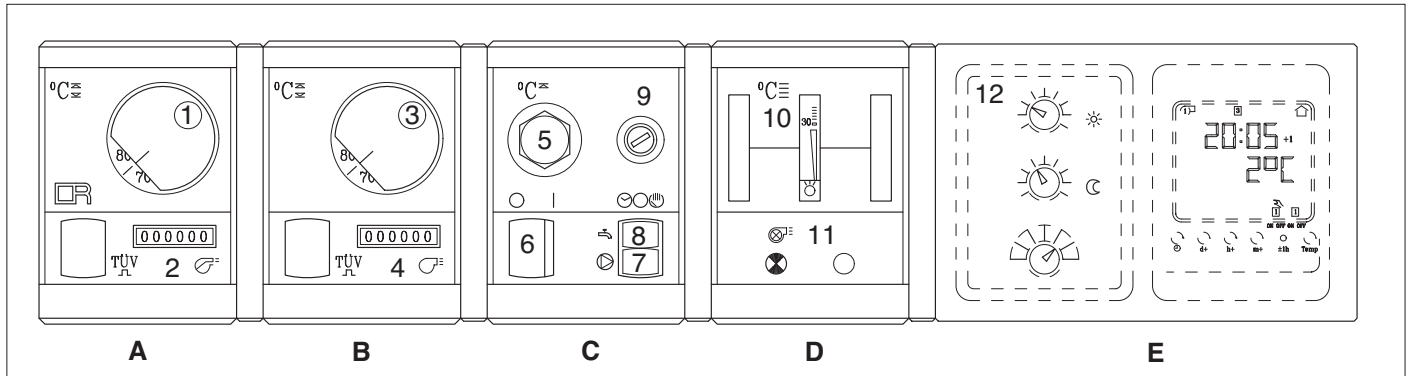

Fig. 05 Instrument panel

The modules contain:

**Module A:**

1. Control thermostat  
Setting between 35°-95°C
2. Hour counter part load

**Module B:**

3. High/Low thermostat  
Setting between 35°C-95°C
4. Hour counter full load

**Module C:**

5. High limit thermostat 110°C (locking)
6. Operating switch (On/Off) with optical display
7. Switch for circulating pump  
Manual/Off/Automatic
8. Switch for domestic hot water storage pump  
Manual/Off/Automatic
9. Fuse 6.3 A MT

**Module D:**

10. Analogue thermometer water temperature
11. Central warning light

**Module E:**

12. Option for **rematic** weather compensated boiler control

Fig. 06 Wiring diagram instrument panel

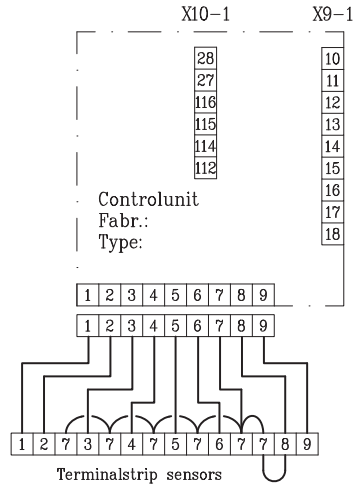

- Legend:
- B - Female connector
  - CT - Control thermostat
  - F - Fuse
  - H - Failure-/Run light
  - HLT - High limit thermostat
  - H/LT - High-low thermostat
  - K1 - Auxiliary relay
  - P1,P2 - Hour run meter
  - S - Male connector
  - S1 - Burner switch
  - S2 - Pump switch heating
  - S3 - Pump switch D.H.W.S.
  - 1.) - Link

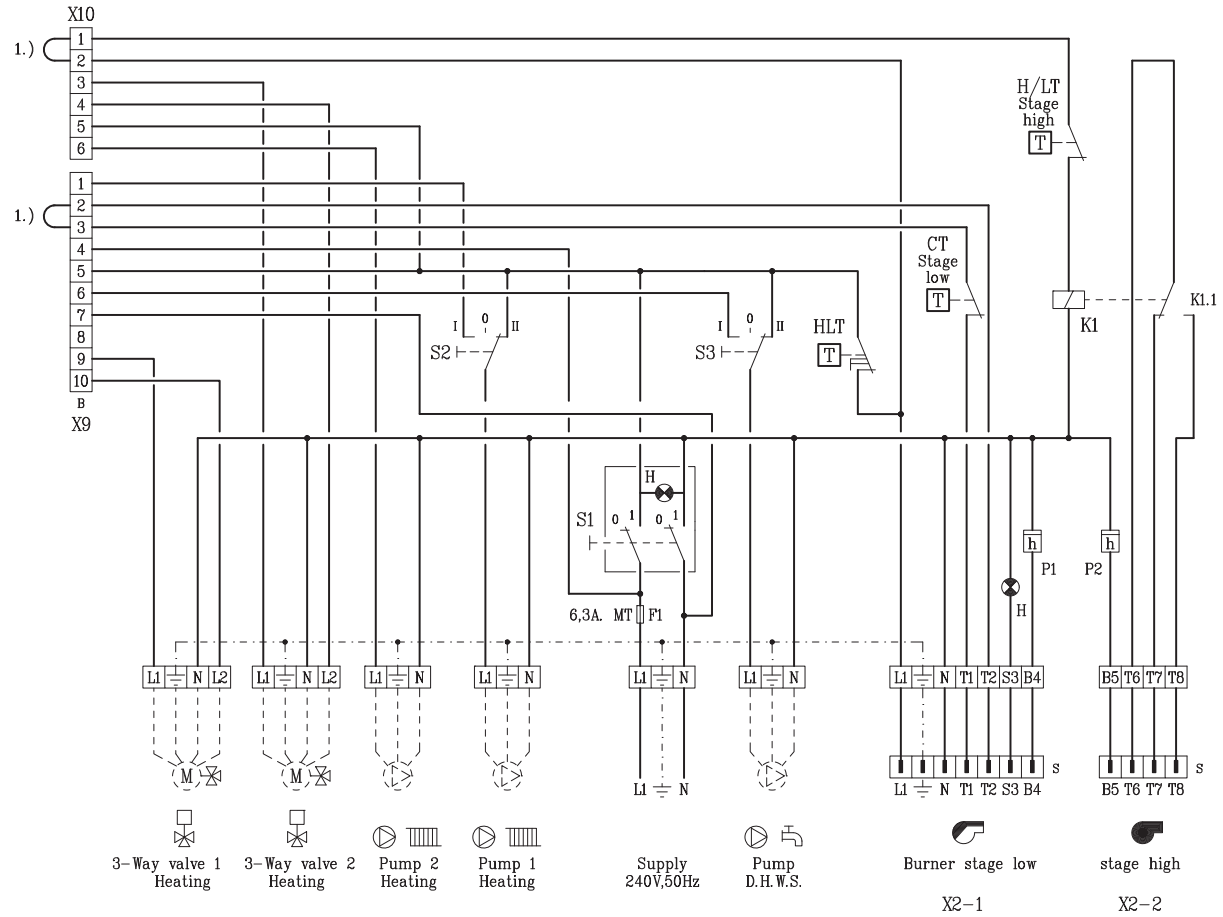
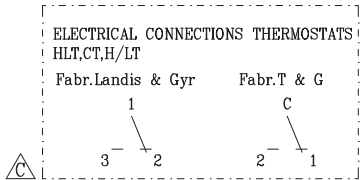

9.1 Wiring diagram instrument panel

9. ELECTRICAL INSTALLATION REQUIREMENTS

## 10. COMMISSIONING

### 10.1 Pressurized boiler with gas burner

#### 10.1.1 Commissioning procedure

If the boiler is to be put into operation again following a period of non-use, then the following procedure must be carried out:

- a. Open the main gas cock.
- b. Switch the weather compensator (if fitted) over to manual operation.
- c. Turn the thermostats to their highest setting.
- d. Switch on the circulating pump.
- e. Switch on the main switch.
- f. Switch on the operation switch in the instrument panel.
- g. Consult burner manufacturer commissioning details.

#### Warning

If the instrument panel is fitted with a weather compensator, set the program switch to 'manual' position. In the event that either a circulation and/or a hot domestic water storage pump are connected to the boiler control, set both pump switches in the 'manual' position. The following will now take place: the gas burner fan will start running so that during the purging time the combustion chamber will be ventilated with fully opened air damper. Then the air damper will go into start up position. Prior flame lights up and is checked. Then the control box gives the all clear signal for the burner to switch over to full load.

#### 10.1.2 Putting out of operation

It is sufficient to switch off the operating switch on the instrument panel. It is recommended that in the event of work being carried out on the burner, the main gas cock is shut.

### 10.2 Pressurized boiler with oil burner

#### 10.2.1 Commissioning procedure

If the boiler is to be put into operation again following a period of non-use, then the following procedure must be carried out:

- a. Open the main oil valve.
- b. Switch the weather compensator (if fitted) over to manual operation.
- c. Turn the thermostats to their highest setting.
- d. Switch on the circulating pump.
- e. Switch on the main switch.
- f. Switch on the operating switch in the control panel.
- g. Consult burner manufacturer commissioning details.

#### Warning

If the instrument panel is fitted with a weather compensator, set the program switch to 'manual' position. In the event that either a circulation and/or a hot domestic water storage pump are connected to the boiler control, set both pump switches in the 'manual' position. The following will now take place: the oil burner fan will start running so that during the purging time the combustion chamber will be ventilated with fully opened air damper. Then the air damper will go into start up position. Ignition flame lights up and is checked. Then the control box gives the all clear signal for the burner to switch over to full load.

#### 10.2.2 Putting out of operation

It is sufficient to switch off the operating switch on the instrument panel. It is recommended that in the event of work being carried out on the burner, the main oil valve is shut.

## 11. FAULT FINDING

### 11.1 High Limit thermostat lockout

- Check the water circulating (circulation pump). Reset the High Limit thermostat ('reset' button is on the instrument panel under the cover cap of the High Limit thermostat).
- If the circulating pump is connected by the instrument panel, check if the pump switch is in 'manual' position. (Never put this switch in 'clock' position, if a weather compensator is not fitted).
- Advise the installer in the event of continued lock outs.

## 12. MAINTENANCE RECOMMENDATIONS

### 12.1 General

Depending on the operating conditions, the block and the burner must be checked and cleaned one or more times a year.

### 12.2 Maintenance instructions

- \* Cleaning of the boiler.
  - Put boiler out of operation.
  - Open the front door, if necessary after dismantling the burner.
  - Remove the retarders.
  - Clean the combustion chamber and flue passes using a suitable brush.
  - Clean the removed retarders.
  - Remove the rear panel of the boiler and remove the cleaning cover (underneath the smoke box).
  - Vacuum clean the boiler and the combustion chamber.
  - Renew the front door seals after cleaning the boiler.
  - Re-assemble the removed parts and close the front door.
  - Re-assemble the burner (if dismantled).
- \* Check the boiler combustion side for leakage.
- \* Check the equipment for proper functioning and if necessary re-adjust the gas control and safety equipment.
- \* Check combustion by means of combustion gas analyses.
- \* Check the water connections.



**Broag Ltd.**

**Head Office**

Remeha House,  
Molly Millars Lane,  
Wokingham,  
Berkshire RG41 2QP  
Tel. 0118 9783434  
Fax 0118 9786977  
Email address:  
boilers@broag.ltd.uk

**Branch Office**

Unit 3, Kestrel Close,  
Quarry Hill Ind. Estate,  
Ilkeston,  
Derbyshire DE7 4RD  
Tel. 0115 9440778  
Fax 0115 9440588

**© Copyright**

All technical and technological information contained in these technical instructions, as well as any drawings and technical descriptions furnished by us remain our property and shall not be multiplied without our prior consent in writing.

# OD15B

## Technical information

Pressurized boiler

Heat output:  
678-1884 kW

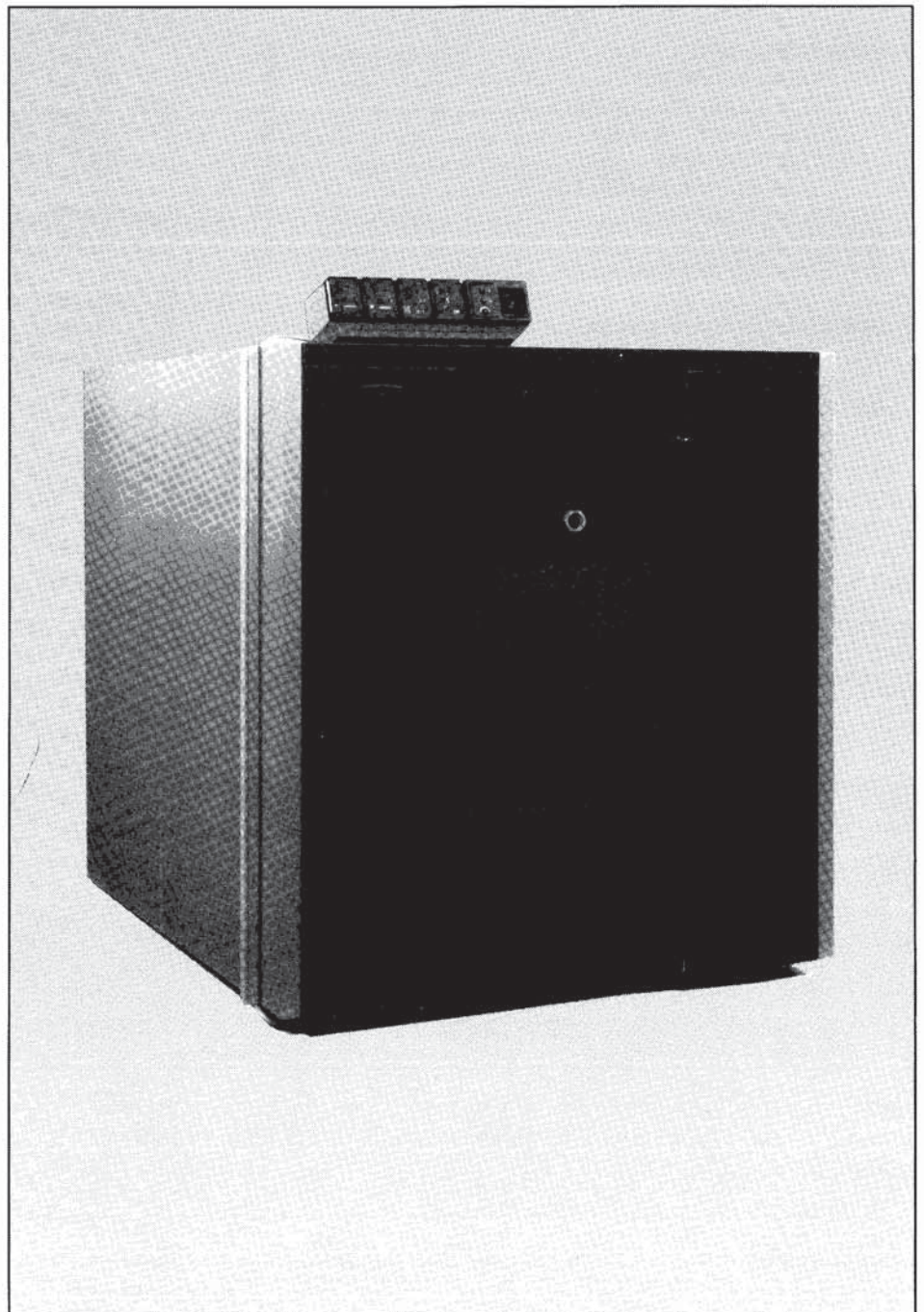



**CONTENTS**

<b>1. Description of the unit</b> .....	3	<b>7. Assembly guidelines and installation requirements</b> .....	6
1.1 General .....	3	7.1 General .....	6
1.2 Burners .....	3	7.2 Boiler assembly .....	6
<b>2. Construction data</b> .....	3	7.3 Water connections .....	6
2.1 General .....	3	<b>8. Instrument panel for OD boilers</b> .....	7
2.2 Sections .....	3	8.1 Equipment contents .....	7
2.3 Casing .....	3	<b>9. Electrical installation requirements</b> .....	8
<b>3. Technical data and dimensions</b> .....	4	9.1 Wiring diagram KSF 101.12 .....	8
<b>4. Output data</b> .....	5	9.2 Wiring diagram KSF 101.51/KSF 101.52 .....	9
4.1 Boiler-efficiency .....	5	<b>10. Start-up regulations</b> .....	10
4.2 Combustion-efficiency .....	5	10.1 Pressurized boiler with gas burner .....	10
<b>5. Application data</b> .....	5	10.1.1 Starting up procedure .....	10
5.1 Hot water version .....	5	10.1.2 Putting out of operation .....	10
5.1.1 Water temperature .....	5	10.2 Pressurized boiler with oil burner .....	10
5.1.2 Water pressure .....	5	10.2.1 Starting up procedure .....	10
5.1.3 Flow rate .....	5	10.2.2 Putting out of operation .....	10
5.1.4 Water treatment .....	5	<b>11. Fault finding</b> .....	11
5.2 Noise-production .....	5	11.1 High limit thermostat lockout .....	11
5.3 Economisers .....	5	<b>12. Maintenance recommendations</b> .....	11
5.4 Flue Gas discharge .....	5	12.1 General .....	11
<b>6. Installation requirements</b> .....	6	12.2 Maintenance instructions .....	11
6.1 Installation recommendations in the boiler-house .....	6		
6.2 Base details .....	6		

## 1. DESCRIPTION OF THE UNIT

### 1.1 General

High efficiency pressurized boiler, suitable for use with natural gas and light oil, by means of a pressure jet burner. Also available with ECO (for natural gas only).

### 1.2 Burners

In principle all pressure jet burners are suitable, subject to prior adjustment to the boiler capacity and boiler construction. The individual boiler satisfies inspection requirement for central heating boilers.

## 2. CONSTRUCTION DATA

### 2.1 General

The boiler block consists of cast iron sections which are assembled by means of tapered nipples. The boiler is designed on the basis of the triple pass principle. The boiler block is insulated with a 100 mm thick layer of glass wool.

### 2.3 Casing

Enamelled steel casing, finished with a high-quality insulation, covered with protective plastic foil. The front door is suitable for left or right opening as desired.

### 2.2 Sections

The sections are made of pearlitic cast iron.

Weights and measures of the sections:

Front section: 220 kg H x W 1252 x 1130 mm

Intermediate section: 250 kg H x W 1238 x 1130 mm

Rear section: 250 kg H x W 1238 x 1130 mm

3. TECHNICAL DATA AND DIMENSIONS

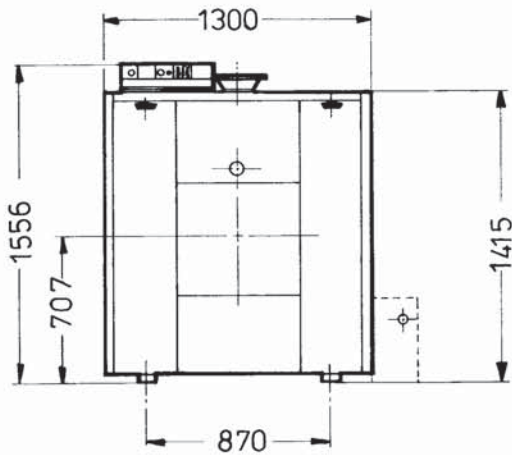

Front view

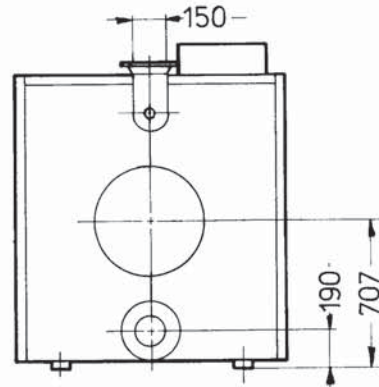

Rear view

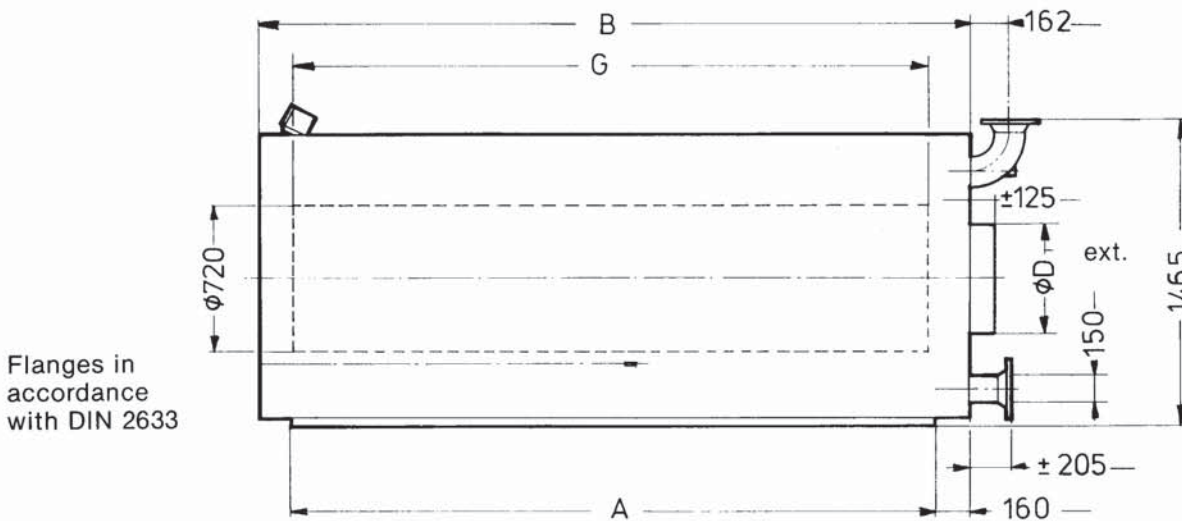

Side view

No. of sections	Nominal heat output kW	Nominal heat input G.C.V. kW	Combustion chamber resistance* mbar	Combustion gas side content m <sup>3</sup>	Water resistance		Water content liters	Weight (dry) approx. kg	Sizes			
					Δt = 20°C	Δt = 10°C			A	B	∅D	G
					mbar	mbar						
8	678	832	1,8	0,9	55	220	440	2390	1200	1510	400	1120
9	779	956	2,5	0,9	56	224	495	2650	1350	1660	400	1270
10	879	1079	3,1	0,9	57	228	550	2910	1500	1810	400	1420
11	980	1202	3,8	1,0	58	232	605	3175	1650	1965	400	1570
12	1080	1325	4,5	1,1	59	237	660	3435	1800	2115	400	1720
13	1182	1450	4,5	1,2	55	220	715	3695	1950	2265	500	1870
14	1282	1573	5,4	1,3	56	224	770	3955	2100	2415	500	2020
15	1382	1696	5,4	1,4	58	233	825	4220	2250	2565	500	2170
16	1482	1819	6,3	1,5	62	250	880	4480	2400	2715	500	2320
17	1583	1942	5,7	1,6	68	272	935	4740	2559	2870	500	2470
18	1684	2066	6,1	1,7	75	301	990	5005	2700	3020	500	2620
19	1784	2189	6,5	1,8	84	337	1045	5265	2850	3170	500	2770
20	1884	2312	6,9	1,9	94	380	1100	5525	3000	3320	500	2920

\*) Determined with 20% excess air.

## 4. OUTPUT DATA

### 4.1 Boiler-efficiency

Approx. 81,5% at GCV (90,5% at NCV) at full load and approx. 83,5% at GCV (92,7% at NCV), at part load. Average water temperature 70°C (80/60°C).

### 4.2 Combustion-efficiency

Approx. 82% at GCV (chimney loss 18%) at full load and approx. 84% at GCV at part load.

## 5. APPLICATION DATA

### 5.1 Hot water version

#### 5.1.1 Water temperature

Maximum water temperature is 110°C. The minimum acceptable return water temperature is, both for gas and oil firing boilers 40°C, at a flow rate corresponding to a  $\Delta t$  of 20°C at nominal heat input.

#### 5.1.2 Water pressure

Maximum pressure 6 bar. The boiler is suitable for open and sealed systems up to a maximum pressure of 6,0 bar and a minimum pressure of 0,8 bar. Installation of the boiler in rooftop or in basement boiler room is possible.

#### 5.1.3 Flow rate

The minimum flow rate through the boiler is obtained from the following formula:

$$\frac{\text{nominal heat output (kW)}}{70} = \text{m}^3/\text{h}$$

#### 5.1.4 Water treatment

Under normal conditions water treatment is not required (see our leaflet on water quality regulations).

### 5.2 Noise-production

The noise level measured at a distance of 1 m around the boiler is approx. 75 to 90 dBA. The noise level at the chimney outlet will, depending on load, type of burner and chimney situation, vary from 75 to 90 dBA, measured at a distance of 1 m from the outlet. If this noise production gives rise to problems in the immediate vicinity, then noise-reducing or absorbing measures should be taken.

### Noise observation OD 15B

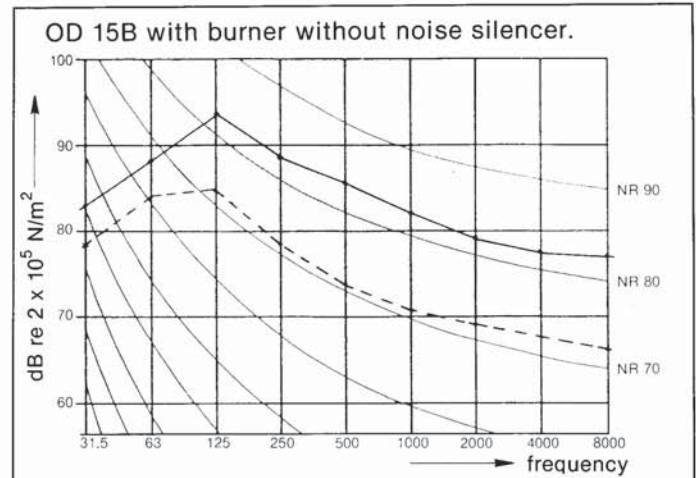

— full load  
- - - part load

The values that have been measured are averages obtained from various measurements carried out at a distance of approx. 1 m around the boiler and at a height of approx. 1 m.

### 5.3 Economisers

ECO's can be delivered upon request. For specifications please refer to Technical Information ECO 13/14/15 (for natural gas only).

### 5.4 Flue gas discharge

For the discharge of the flue gasses, chimney draught is not required.

Tests have shown that very good combustion results are obtained with zero draught at the boiler outlet.

## 6. INSTALLATION REQUIREMENTS

### 6.1 Installation recommendations in the boiler house

The necessary minimum installation space of the boiler can be seen from the figure below.

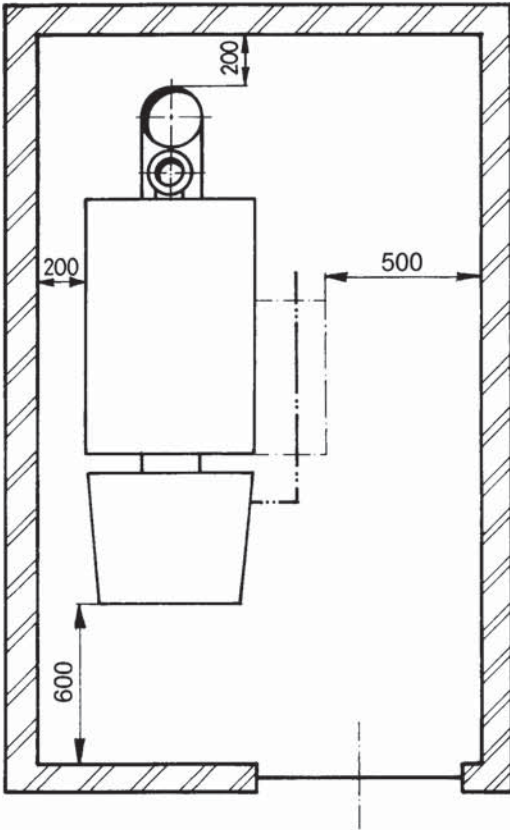

### 6.2 Base details

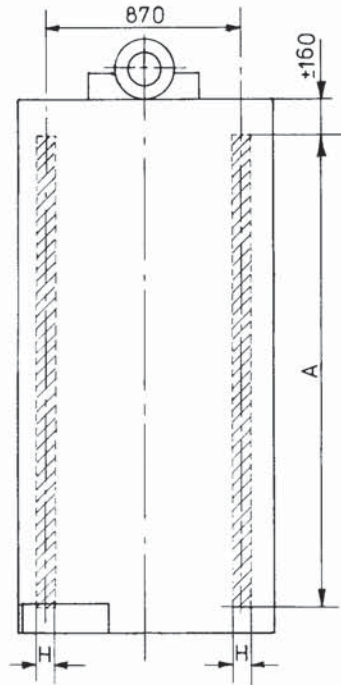

Number of sections	A mm
8	1200
9	1350
10	1500
11	1650
12	1800
13	1950
14	2100
15	2250
16	2400
17	2550
18	2700
19	2850
20	3000

H = 80 mm without vibration damper.  
H = 120 mm with vibration damper.

## 7. ASSEMBLY GUIDELINES AND INSTALLATION REQUIREMENTS

### 7.1 General

The boiler OD 15B is delivered in individual parts. The sizes are such that all parts can enter the boilerhouse through a normal door entrance. The casing and equipment parts are delivered in packaged units. If necessary, the boiler can be put into operation without casing. The casing can be added at a later stage without dismantling the water connections.

### 7.2 Boiler assembly

Assembly and installation of the boiler may only take place by a recognized and approved engineer and in accordance with the assembly manual. Local regulations laid down by the relevant authorities must be adhered to.

### 7.3 Water connections

The water connections are at the back of the boiler. The flow and return connections consist of a flanged flow elbow and flanged return connection in accordance with DIN 2633.

The top flange at the front of the boiler is provided with 3 x G 1/2" threaded holes for the fitting of the thermostat pockets. The return connection is provided with a G 3/4" threaded hole in which a drain off cock is fitted.

## 8. INSTRUMENT PANEL FOR OD BOILERS

### 8.1 Equipment contents

The instrument panel can be delivered in three models:

KSF 101.51 simple instrument panel	On/Off
KSF 101.52 simple instrument panel	High/Low
KSF 101.12 complete instrument panel	High/Low

The instrument panel consists of modules. The modules contain all the necessary control and measuring instruments required to regulate the boiler. All connections are pre-wired and fitted with plugs. The capillaries and feeler wires, which come from the control panel, are placed in the immersion pockets that are fitted at the front of the boiler.

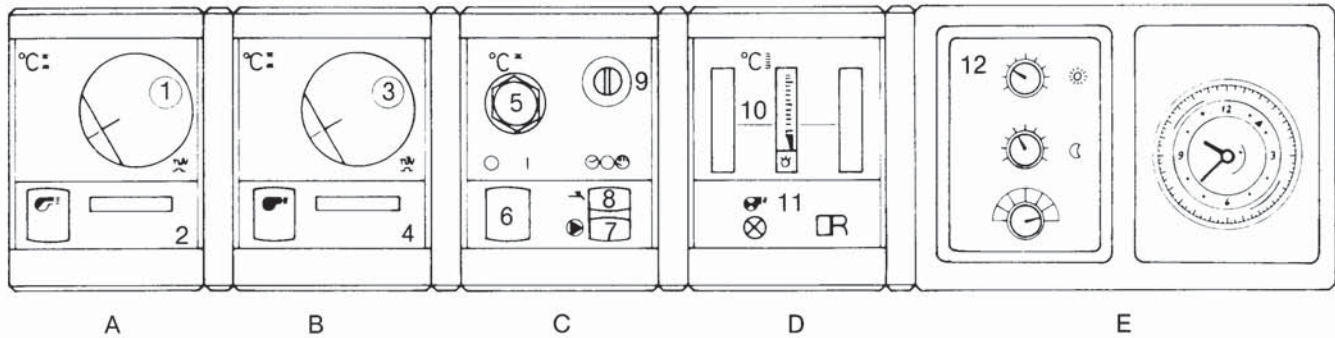

Layout of the complete instrument panel KSF 101.12

The modules contain:

#### Module A

1. Control thermostat  
Setting between 35° - 95°C
2. Hour counter part load\*

#### Module B

3. High/Low thermostat\*\*  
Setting between 35° - 95°C
4. Hour counter full load\*

#### Module C

5. High limit thermostat 110°C (locking)
6. Operating switch (On/Off) with optical display\*
7. Switch for circulating pump\*  
Manual/Off/Automatic
8. Switch for domestic hot water storage pump\*  
Manual/Off/Automatic
9. Fuse 6.3 A MT\*

#### Module D

10. Analogue thermometer water temperature
11. Central warning light\*

#### Module E

12. Option for *rematic* weather compensator\*

\* Absent in simple instrument panel KSF 101.51 and KSF 101.52.

\*\* Absent in simple instrument panel KSF 101.51.

9. ELECTRICAL INSTALLATION REQUIREMENTS

9.1 Wiring diagram complete instrument panel  
KSF 101.12 High/Low

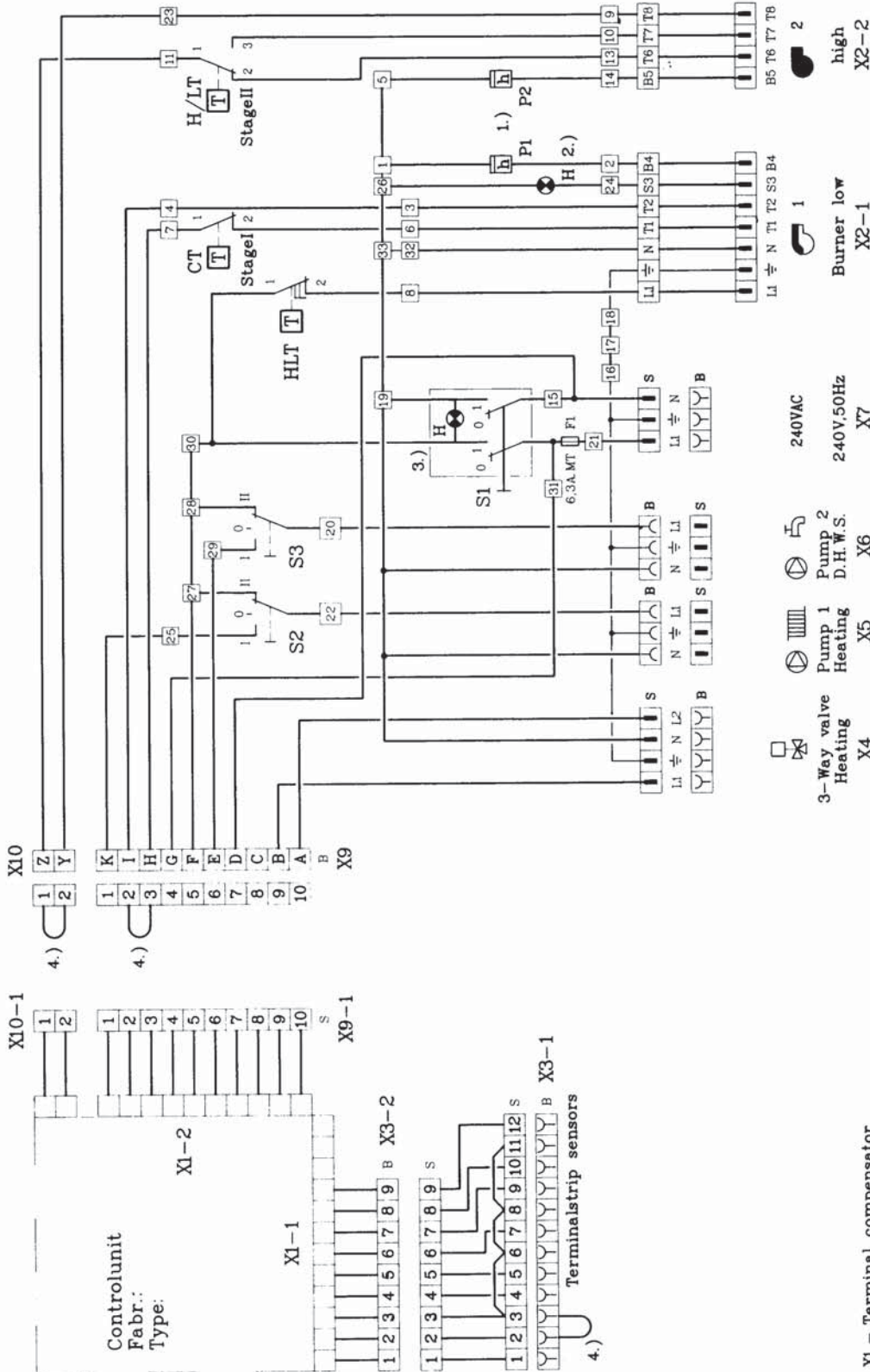





## 10. START-UP REGULATIONS

### 10.1 Pressurized boiler with gas burner

#### 10.1.1 Starting up procedure

If the boiler is to be put into operation again following a period of non-use, then the following procedure must be carried out:

- a. Open the main gas cock.
- b. Switch the weather-compensator (if fitted) over to manual operation.
- c. Switch the thermostats to their highest setting.
- d. Switch on the circulation pump.
- e. Switch on the main switch.
- f. Switch on the operation switch in the instrument panel.
- g. Consult burner manufacturer commissioning details

#### Warning

If the instrument panel is fitted with a weather-compensator boiler control, set the programm switch to 'manual' position. In the event that either a circulation and/or a D.H.W. pump are connected to the boiler control, set both pump switches in the 'manual' position. (These two switches are only fitted in the complete instrument panel KSF 101.12 next to the operating switch.) The following will now take place: the gas burner fan will start running so that during the purging time the combustion chamber will be ventilated with fully opened air damper. Then the air damper will go into start up position. Ignition flame lights up and is checked. Then the control box gives the all clear signal for the burner to switch over to full load.

#### 10.1.2 Putting out of operation

It is sufficient to switch off the operation switch on the instrument panel. It is recommended that in the event of work being carried out on the burner, the main gas cock is shut.

### 10.2 Pressurized boiler with oil burner

#### 10.2.1 Starting up procedure

If the boiler is to be put into operation again following a period of non-use, then the following procedure must be carried out:

- a. Open the main oil cock.
- b. Switch the weather-compensator (if fitted) over to manual operation.
- c. Switch the thermostats to their highest setting.
- d. Switch on the circulation pump.
- e. Switch on the main switch.
- f. Switch on the operation switch in the control panel.
- g. Consult burner manufacturer commissioning details

#### Warning

If the instrument panel is fitted with a weather-compensator boiler control, set the programm switch to 'manual' position. In the event that either a circulation and/or a D.H.W. pump are connected to the boiler control, set both pump switches in the 'manual' position. (These two switches are only fitted in the complete control panel KSF 101.12 next to the operating switch.) The following will now take place: the oil burner fan will start running so that during the purging time the combustion chamber will be ventilated with fully opened air damper. Then the air damper will go into start up position. Ignition flame lights up and is checked. Then the control box gives the all clear signal for the burner to switch over to full load.

#### 10.2.2 Putting out of operation

It is sufficient to switch off the operation switch on the instrument panel. It is recommended that in the event of work being carried out on the burner, the main oil valve is shut.

## 11. FAULT FINDING

### 11.1 High Limit thermostat lockout

- Check the water circulation (circulation pump). Reset the High Limit thermostat (Reset button is on the instrument panel under the cover cap of the High Limit thermostat).
- If the circulation pump is connected via the instrument panel, check if the pump switch is in 'manual' position. (Never put this switch in 'clock' position, if a weather compensator is not fitted).
- Advise the installer in the event of continued lock outs.

## 12. MAINTENANCE RECOMMENDATIONS

### 12.1 General

Depending on the operational conditions, the block and the burner must be checked and cleaned one or more times a year.

### 12.2 Maintenance instructions

- \* Cleaning of the boiler
  - Put boiler out of operation.
  - Open the front door, if necessary after dismantling the burner.
  - Remove the retarders (only for 8 to 16 sections).
  - Clean the combustion chamber and flue passes using a suitable brush (available from Broag).
  - Clean the removed retarders (8 to 16 sections).
  - Remove the rear panel of the boiler and remove the cleaning cover (underneath the smoke box).
  - Vacuum clean the boiler and the combustion gas chamber.
  - Renew the front door seals after cleaning the boiler.
  - Re-assemble the removed parts and close the front door.
  - Re-assemble the burner (if dismantled).
- \* Check the boiler combustion side for leakage.
- \* Check the equipment for proper functioning and if necessary re-adjust the gas control and safety equipment.
- \* Check combustion by means of combustion gas analyses.
- \* Check the water connections.

## Broag Ltd

### Head Office

Molly Millars Lane,  
Wokingham, Berks.  
RG11 2PY.  
Tel. 0734-783434  
Telex 849137  
Fax 0734-786977

### Branch Office

Unit 3  
Kestrel Close Quarry Hill  
Industrial Estate  
ILKESTON Derbyshire  
Tel. (0602) 44 07 78

MANUFACTURED  
BY A



**Ours is a policy of continuous  
development. We reserve the  
right to alter specifications  
without prior notification.**

# remeha OD 15C    Technical information

**Pressurized boiler**

**Heat output:  
635 - 1900 kW**



## CONTENTS

<b>Preface</b>	3	<b>7. Assembly guidelines and installation instructions</b>	7
<b>1. Description of the unit</b>	3	7.1 General	7
1.1 General	3	7.2 Boiler assembly	7
1.2 Burners	3	7.3 Water connections	7
<b>2. Construction data</b>	3	<b>8. Instrument panel</b>	8
2.1 General	3	8.1 Equipment contents	8
2.2 Sections	3	8.2 Wiring diagram	9
2.3 Casing	3	<b>9. Lighting instructions</b>	10
<b>3. Technical data and dimensions</b>	4	9.1 Pressurized boiler with gas burner	10
<b>4. Output data</b>	5	9.1.1 Start up	10
4.1 Boiler-efficiency	5	9.1.2 Shutdown	10
4.2 Combustion-efficiency	5	9.2 Pressurized boiler with oil burner	10
<b>5. Application data</b>	5	9.2.1 Start up	10
5.1 Hot water version	5	9.2.2 Shutdown	10
5.1.1 Water temperature	5	<b>10. Fault finding</b>	11
5.1.2 Water pressure	5	10.1 High Limit thermostat lock out	11
5.1.3 Flow rate	5	<b>11. Maintenance instructions</b>	11
5.1.4 Water treatment	5	11.1 General	11
5.2 Noise-production	5	11.2 Maintenance instructions	11
5.3 Condensing units	5		
5.4 Flue gas discharge	5		
<b>6. Installation instructions</b>	6		
6.1 Clearances	6		
6.2 Base details	6		

## PREFACE

These technical instructions contain useful and important information for the proper operation and maintenance of the central heating boiler, model remeha OD 15C. Further it contains important directions to prevent accidents and serious damage before putting it into service and during operation of the boiler, to permit as much as possible a safe and trouble-free operation. Read these instructions carefully before putting the boiler into service, familiarize yourself with its operation and control and strictly observe the directions given.

If you have any questions, or if you want more information about specific items relating to this boiler, please do not hesitate to contact us.

The data published in these technical instructions is based on the most recent information and is given subject to later revisions.

We reserve the right to modify the construction and/or design of our products at any moment, without obligation to update earlier supplies accordingly.

## 1. DESCRIPTION OF THE UNIT

### 1.1 General

High efficiency pressurized boiler, suitable for use with natural gas and light oil, by means of a pressure jet burner. Also available with ECO (for natural gas only).

The boiler meets the requirements of the CE regulations is the following directives:

- Gas appliance directive no. 90/396/EEC
- Electrical low voltage directive no. 73/23/EEC
- Machinery directive no. 89/392/EEC
- E.M.C. directive no. 89/336/EEC
- Efficiency directive 92/42/EEC.

Classification type for evacuation of the combustion products: B23.

PIN: 0063AR3337

### 1.2 Burners

In principle all pressure jet burners are suitable, subject to prior adjustment to the boiler capacity and boiler construction. The individual boiler satisfies inspection requirement for central heating boilers.

## 2. CONSTRUCTION DATA

### 2.1 General

The boiler block consists of cast iron sections which are assembled by means of tapered nipples. The boiler is designed on the basis of the triple pass principle. The boiler block is insulated with a 100 mm thick layer of glass wool.

### 2.2 Sections

The sections are made of perlitic cast iron.

Weights and measures of the sections:

Front section	: 220 kg	H x W	1252 x 1130 mm
Intermediate section	: 250 kg	H x W	1238 x 1130 mm
Rear section	: 220 kg	H x W	1238 x 1130 mm

### 2.3 Casing

Enamelled steel casing, finished with a high-quality insulation, covered with protective plastic foil. The front door is suitable for left or right opening as desired.

## 3. TECHNICAL DATA AND DIMENSIONS

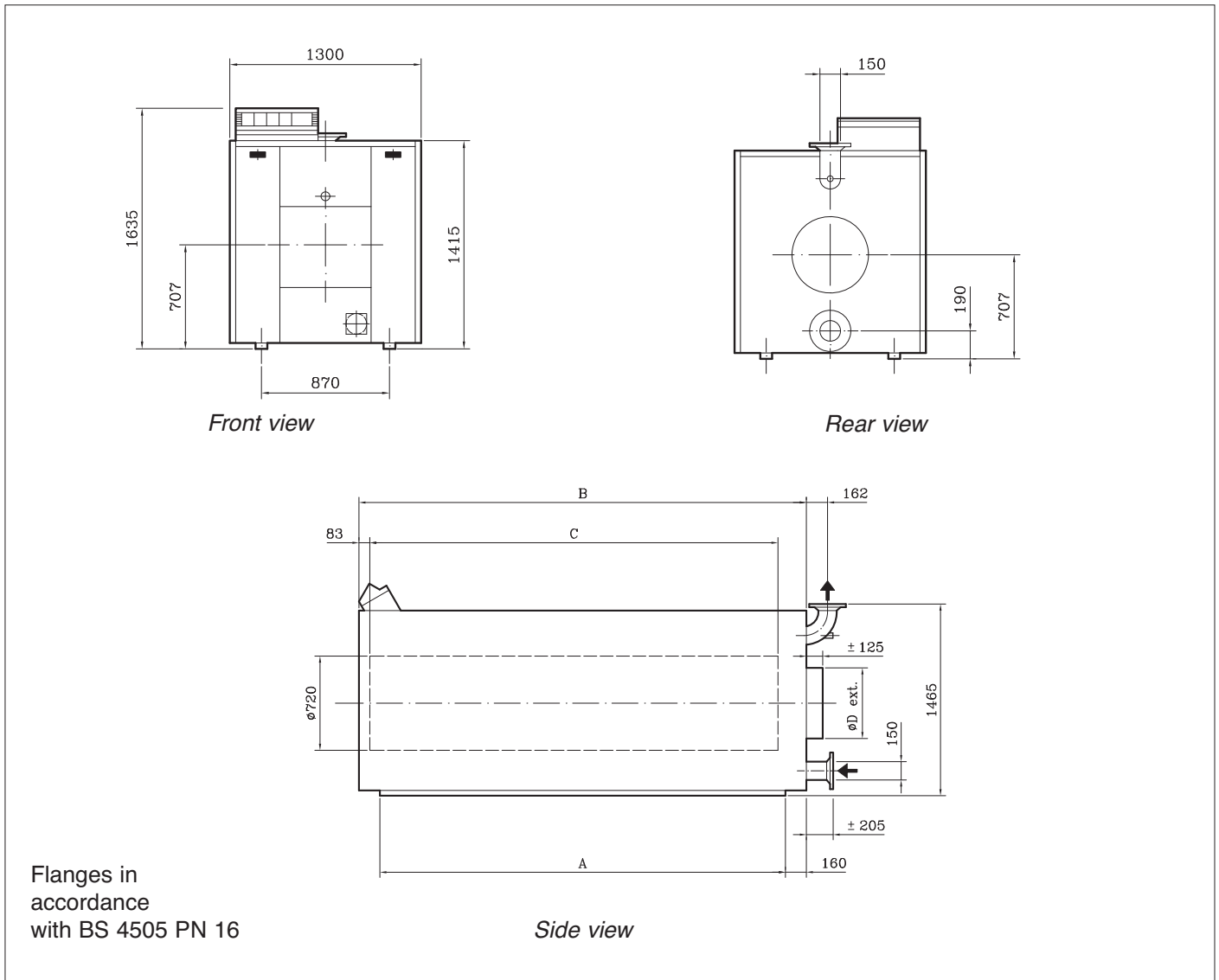

Fig. 01 Dimensions

Number of sections	Nominal heat output kW	Nominal heat input		Combustion Chamber resistance* mbar	Combustion gas side content m <sup>3</sup>	Water resistance		Water content litres	Weight (dry) approx. kg	Fluegas mass rate kg/h	Sizes			
		kW-Nc <sub>v</sub>	kW/G <sub>c</sub> <sub>v</sub>			$\Delta t = 20^{\circ}\text{C}$	$\Delta t = 10^{\circ}\text{C}$				A	B	C	$\phi D$
						mbar	mbar				mm	mm	mm	mm
9	635	706	784	1.7	0.8	37	149	495	2650	1102	1350	1660	1270	400
10	750	834	926	2.3	0.9	42	166	550	2910	1302	1500	1810	1420	400
11	865	962	1068	3.0	1.0	45	180	605	3175	1502	1650	1965	1570	400
12	980	1090	1210	3.8	1.1	49	194	660	3435	1702	1800	2115	1720	400
13	1095	1218	1352	3.9	1.2	47	189	715	3695	1901	1950	2265	1870	500
14	1210	1341	1488	4.8	1.3	50	200	770	3955	2081	2100	2415	2020	500
15	1325	1468	1630	5.0	1.4	53	213	825	4220	2292	2250	2565	2170	500
16	1440	1592	1767	5.9	1.5	59	234	880	4480	2485	2400	2715	2320	500
17	1555	1719	1908	5.5	1.6	66	262	935	4740	2683	2559	2870	2470	500
18	1670	1846	2049	6.0	1.7	74	295	990	5005	2882	2700	3020	2620	500
19	1785	1973	2190	6.5	1.8	84	337	1045	5265	3080	2850	3170	2770	500
20	1900	2100	2331	7.0	1.9	96	382	1100	5525	3278	3000	3320	2920	500

\* Determined with 20% excess air

## 4. OUTPUT DATA

### 4.1 Boiler-efficiency

Approx. 90.2% at NCV (81.3% at GCV) at full load and approx. 92.5% at NCV (83.3% at GCV), at part load. Average water temperature 70°C (80/60°C).

### 4.2 Combustion-efficiency

Approx. 91.4% at NCV (82.3% at GCV) at full load and approx. 92.9% at NCV (83.7% at GCV) at part load.

## 5. APPLICATION DATA

### 5.1 Hot water version

#### 5.1.1 Water temperature

Maximum water temperature is 110°C. The minimum acceptable return water temperature is, both for gas and oil firing boilers 40°C at nominal heat input.

#### 5.1.2 Water pressure

Maximum pressure 6 bar. The boiler is suitable for open and sealed systems up to a maximum pressure of 6.0 bar and a minimum pressure of 0.8 bar. Installation of the boiler in rooftop or in a basement boiler room is possible.

#### 5.1.3 Flow rate

The minimum flow rate through the boiler is obtained from the following formula:

$$\frac{\text{nominal heat output (kW)}}{70} = \text{m}^3/\text{h}$$

This minimum flow must be maintained for 5 minutes after the burner stops firing to avoid high temperature shut-down due to residual heat gain. Due to the design and manufacture of the boiler no specific minimum water flow requirement exists other than for over-temperature.

#### 5.1.4 Water treatment

Under normal conditions water treatment should not be required (see our leaflet on water quality regulations).

### 5.2 Noise-production

The noise level measured at a distance of 1 m around the boiler is approx. 75 to 90 dBA. The noise level at the chimney outlet will, depending on load, type of burner and chimney situation, vary from 75 to 90 dBA, measured at a distance of 1 m from the outlet. If this noise production gives rise to problems in the immediate vicinity, then noise-reducing or absorbing measures should be taken.

### Noise measurement remeha OD 15C

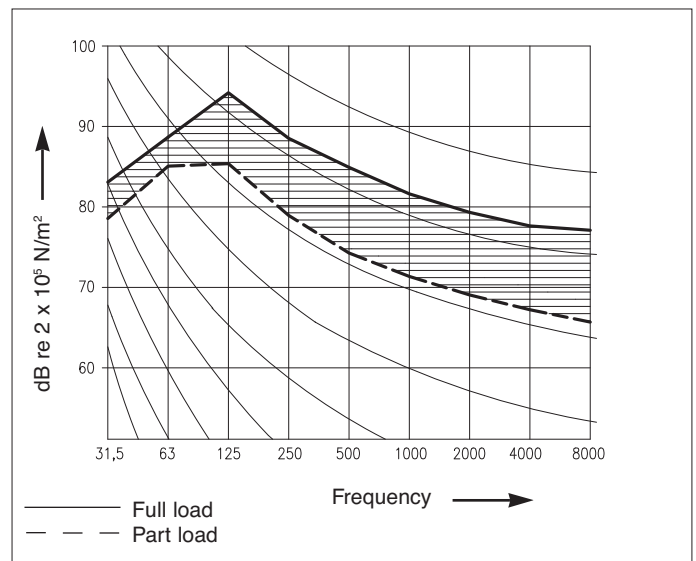

Fig. 02 remeha OD 15C noise production

The values that have been measured are averages obtained from various measurements carried out at a distance of approx. 1 m around the boiler and at a height of approx. 1 m.

### 5.3 Condensing units

ECO's can be delivered upon request. For specifications please refer to Technical Information ECO 13/14/15 (for natural gas only).

### 5.4 Flue gas discharge

For the discharge of the flue gasses, chimney draught is not required.

Tests have shown that very good combustion results are obtained with zero draught at the boiler outlet.



## 6. INSTALLATION INSTRUCTIONS

### 6.1 Clearances

We recommend to keep the following free space around the boiler as shown in figure below.

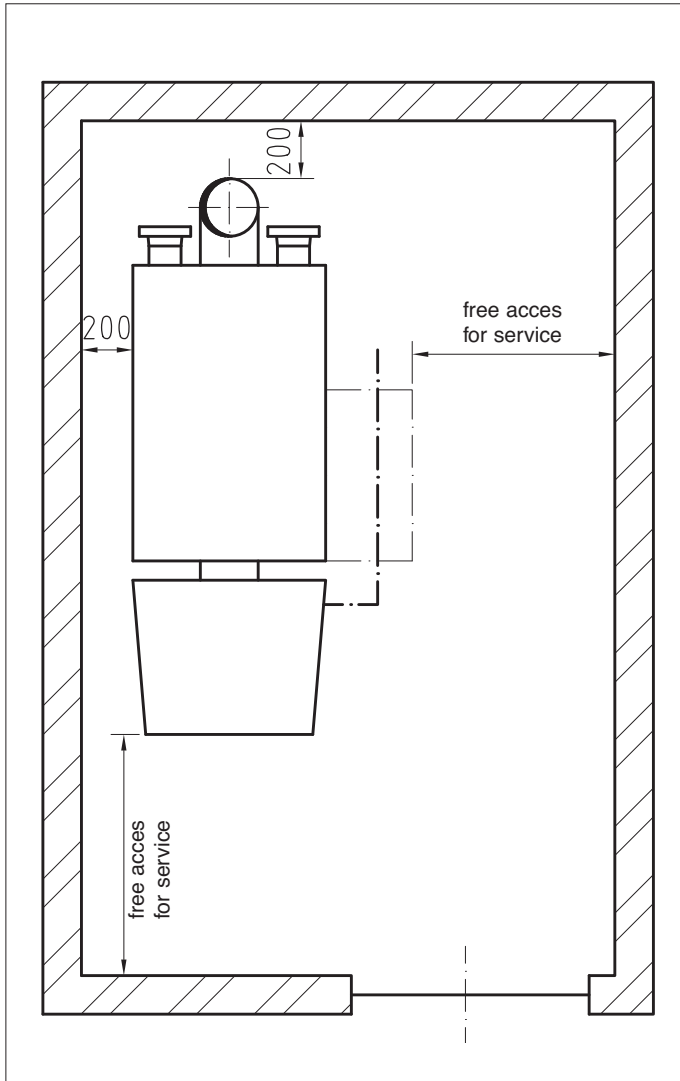

Fig. 03 Installation

### 6.2 Base details

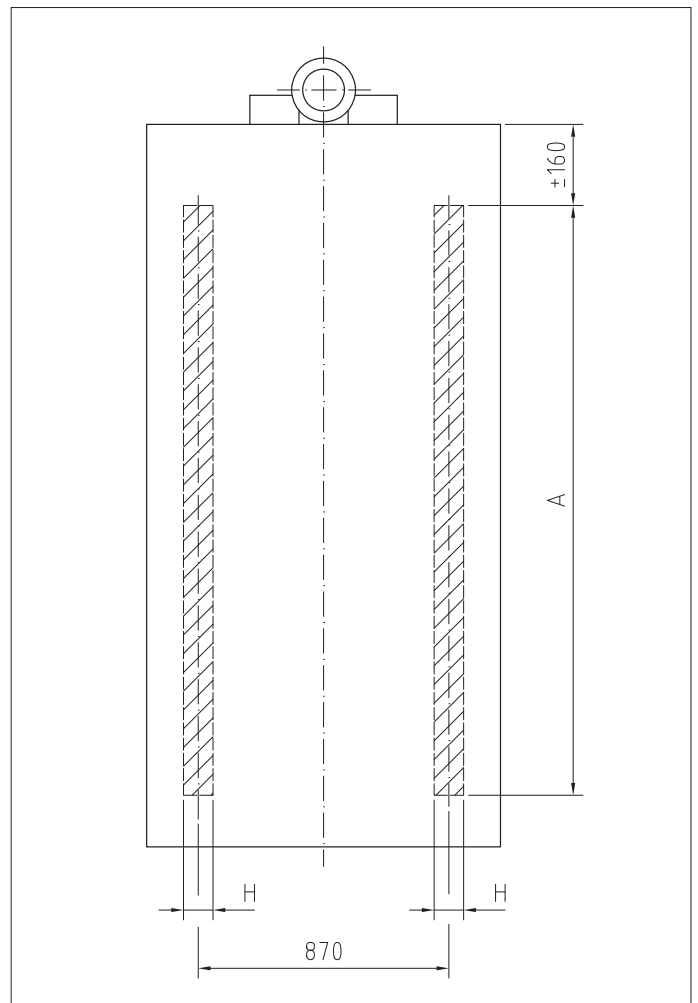

Fig. 04 Base details

H = 80 mm without vibration damper

H = 120 mm with vibration damper

Number of sections	A mm
9	1350
10	1500
11	1650
12	1800
13	1950
14	2100
15	2250
16	2400
17	2550
18	2700
19	2850
20	3000

## 7. ASSEMBLY GUIDELINES AND INSTALLATION INSTRUCTIONS

### 7.1 General

The boiler remeha OD 15C is delivered in individual parts. The sizes are such that all parts can enter the boiler house through a normal door entrance. The casing and equipment parts are delivered in packaged units. If necessary, the boiler can be put into operation without casing. The casing can be added at a later stage without disconnecting the boiler.

### 7.2 Boiler assembly

Assembly and installation of the boiler may only be undertaken by a recognized and approved engineer and in accordance with the assembly manual. Local regulations laid down by the relevant authorities must be adhered to.

### 7.3 Water connections

The water connections are at the back of the boiler. The flow and return connections consist of a flanged flow elbow and flanged return connection in accordance with DIN 2633.

The top flange at the front of the boiler is provided with 3 x G 1/2" threaded holes for the fitting of the thermostat pockets. The return connection is provided with a G 3/4" threaded hole in which a drain off cock is fitted.

## 8. INSTRUMENT PANEL

### 8.1 Equipment contents

The instrument panel consists of modules. The modules contain all the necessary control and measuring instruments required to regulate the boiler.

All connections are pre-wired and fitted with plugs. The thermostat bulbs are placed in the immersion pockets fitted at the front of the boiler.

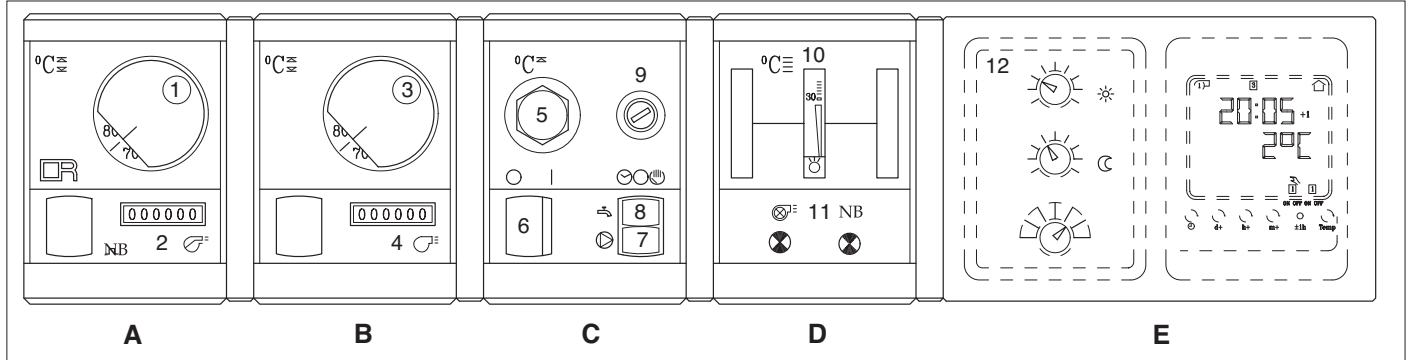

Fig. 05 Layout of the instrument panel, type KSF 101.102

The modules contain:

#### Module A

1. Control thermostat. Setting between 35°-95°C
2. Hour counter part load

#### Module B

3. High/Low thermostat. Setting between 35°-95°C
4. Hour counter full load

#### Module C

5. High limit thermostat 110°C (locking)
6. Operating switch (On/Off) with optical display
7. Switch for circulating pump  
Manual/Off/Automatic
8. Switch for domestic hot water storage pump  
Manual/Off/Automatic
9. Fuse 6.3A MT

#### Module D

10. Analogue thermometer water temperature
11. Central warning light

#### Module E

12. Option for *rematic*<sup>®</sup> weather compensator

Fig. 06 Wiring diagram of the remeha OD 15C

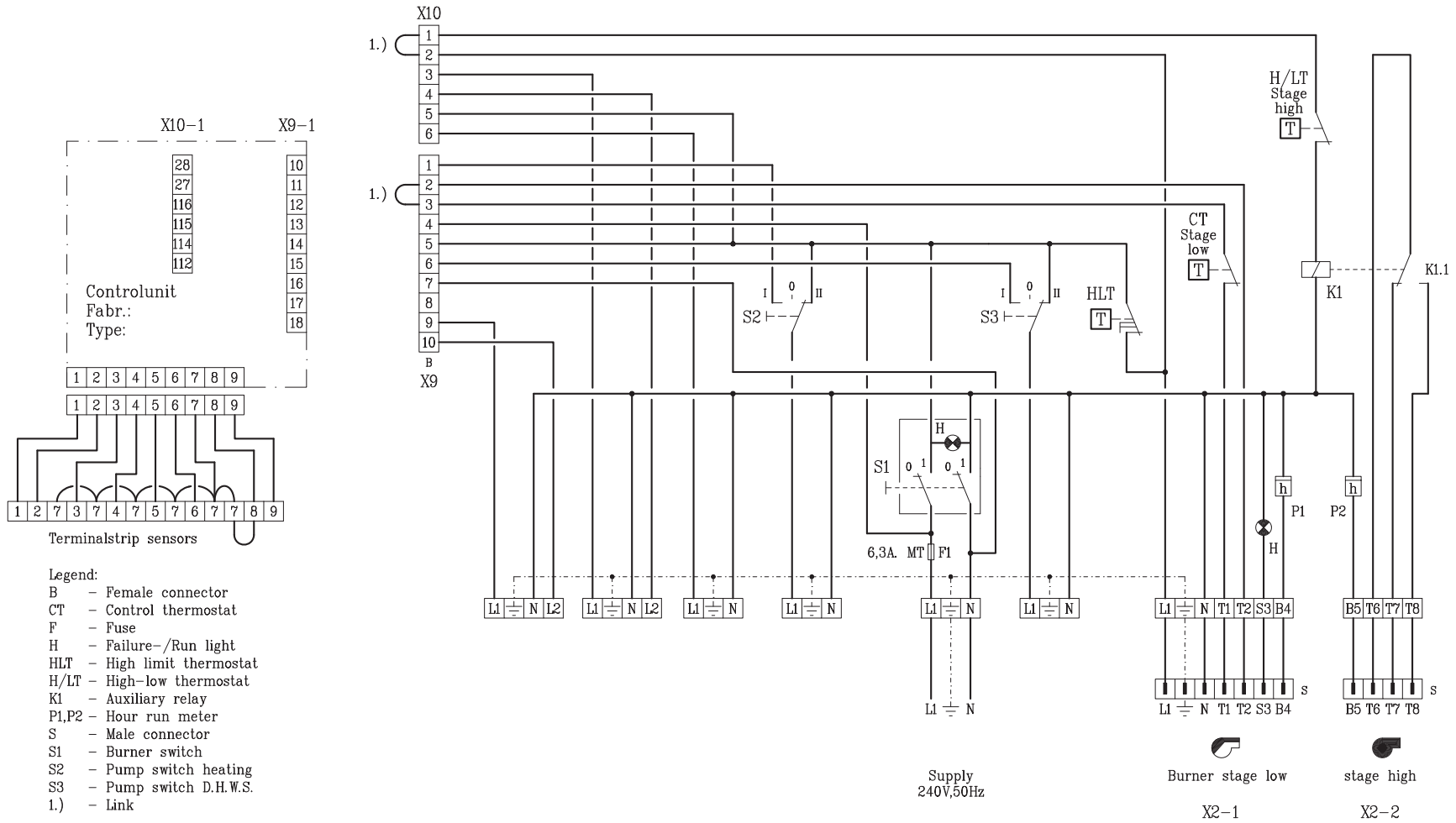

## 9. LIGHTING INSTRUCTIONS

### 9.1 Pressurized boiler with gas burner

#### 9.1.1 Start up

If the boiler is to be put into operation again following a period of non-use, then the following procedure must be carried out:

- a. Open the main gas cock.
- b. Switch the weather-compensator (if fitted) over to manual operation.
- c. Switch the thermostats to their highest setting.
- d. Switch on the circulation pump.
- e. Switch on the main switch.
- f. Switch on the operation switch in the instrument panel.
- g. Consult burner manufacturers commissioning details.

#### Warning

If the instrument panel is fitted with a weather-compensator, set the programme switch to 'manual' position. In the event that either a circulation and/or D.H.W. pump are connected to the boiler control, set both pump switches in the 'manual' position (these two switches are only fitted in the complete instrument panel KSF 101.102 next to the operating switch).

The following will now take place: the gas burner fan will start running so that during the purging time the combustion chamber will be ventilated with fully opened air damper. Then the air damper will go into start up position. Ignition flame lights up and is checked. Then the control box gives the all clear signal for the burner to switch over to full load.

#### 9.1.2 Shutdown

It is sufficient to switch off the operation switch on the instrument panel. It is recommended that in the event of work being carried out on the burner, the main gas cock is shut.

### 9.2 Pressurized boiler with oil burner

#### 9.2.1 Start up

If the boiler is to be put into operation again following a period of non-use, then the following procedure must be carried out:

- a. Open the main oil cock.
- b. Switch the weather-compensator (if fitted) over to manual operation.
- c. Switch the thermostats to their highest setting.
- d. Switch on the circulation pump.
- e. Switch on the main switch.
- f. Switch on the operation switch in the control panel.
- g. Consult burner manufacturer for commissioning details.

#### Warning

If the instrument panel is fitted with a weather-compensator, set the programme switch to 'manual' position. In the event that either a circulation and/or D.H.W. pump are connected to the boiler control, set both pump switches in the 'manual' position (these two switches are only fitted in the complete control panel KSF 101.102 next to the operating switch).

The following will now take place: the oil burner fan will start running so that during the purging time the combustion chamber will be ventilated with fully opened air damper. Then the air damper will go into start up position. Ignition flame lights up and is checked. Then the control box gives the all clear signal for the burner to switch over to full load.

#### 9.2.2 Shutdown

It is sufficient to switch off the operation switch on the instrument panel. It is recommended that in the event of work being carried out on the burner, the main oil valve is shut.

## 10. FAULT FINDING

### 10.1 High Limit thermostat lock out

- Check the water circulation (circulation pump).  
Reset the High Limit thermostat (Reset button is on the instrument panel under the cover cap of the High Limit thermostat).
- If the circulation pump is connected via the instrument panel, check if the pump switch is in 'manual' position. (Never put this switch in 'clock' position, if a weather compensator is not fitted).
- Advise the installer in the event of continued lock outs.

## 11. MAINTENANCE INSTRUCTIONS

### 11.1 General

Depending on the operational conditions, the block and the burner must be checked and cleaned at least once a year.

### 11.2 Maintenance instructions

- \* Cleaning of the boiler.
  - Switch off the boiler.
  - Open the front door, if necessary after dismantling the burner.
  - Remove the retarders (only for 9 to 16 sections).
  - Clean the combustion chamber and flue passes using a suitable brush.
  - Clean the removed retarders (only for 9 to 16 sections).
  - Remove the rear panel of the boiler and remove the cleaning cover (underneath the smoke box).
  - Vacuum clean the boiler and the combustion gas chamber.
  - Renew the front door seals after cleaning the boiler.
  - Re-assemble the removed parts and close the front door.
  - Re-assemble the burner (if dismantled).
- \* Check the boiler combustion side for leakage.
- \* Check the equipment for proper functioning and if necessary re-adjust the gas control and safety equipment.
- \* Check combustion by means of combustion gas analysis.
- \* Check the water connections.



**Broag Ltd.**

**Head Office**

Remeha House,  
Molly Millars Lane,  
Wokingham,  
Berkshire RG41 2QP  
Tel. 0118 9783434  
Fax 0118 9786977  
Email: [boilers@broag.ltd.uk](mailto:boilers@broag.ltd.uk)

**Branch Office**

Unit 3, Kestrel Close,  
Quarry Hill Ind. Estate,  
Ilkeston,  
Derbyshire DE7 4RD  
Tel. 0115 9440778  
Fax 0115 9440588

**© Copyright**

All technical and technological information contained in these technical instructions, as well as any drawings and technical descriptions furnished by us remain our property and shall not be multiplied without our prior consent in writing.